

ROUND TOOL MATERIALS

2020 EN

p-line

programme



CERATIZIT is a high-technology engineering group specialised in cutting tools and hard material solutions.

Tooling the Future

ceratizit.com

Dear customers,

CERATIZIT Group develops and produces innovative solutions for tool manufacturers. Based on your requirements and the desired price point, when it comes to tool production you can choose from three different product lines:

p-line

The p-line (Premium line) includes the largest selection of grades and designs and is suitable for every kind of application with high-performance tools. Our p-line products are exclusively manufactured using carbide grades which are produced at our company sites in Reutte, Austria, or Warren, in the USA. You can choose from 12 standard grades, ranging from ultra-fine to submicron and fine grain, as well as cermet grades. With over 1,100 stock products in 25 different variants we offer you the largest stock range worldwide for manufacturers of solid carbide tools.

Of course we can also supply you with individual near net shape preforms and semi-finished tools based on your drawings, with timely deliveries.

CERATIZIT gives you a unique complete package, with outstanding performance in all fields – from the development to the product, along with ready availability and service.

Highly developed logistics processes

You can count on our high and flexible production capacity for stock products: an optimally stocked warehouse ensures that your order will always be dealt with swiftly and reliably. You can order stock products without any problem 24/7 online from our E-Techstore, and take advantage of the technical expertise of our sales and office staff. With over 50 company sites in Europe, America and Asia, we are available for you at any time throughout the world.



Contents

INTRODUCTION

CERATIZIT Group	6
Production site	7
Supreme availability	9
Cemented carbide	10
Grades: composition and properties	16
Designation system	20
Stock programme at a glance	22

SOLID CARBIDE RODS 24

As sintered	25
Ground, metric	29
Ground, inch	32

END MILL BLANKS 34

Metric	35
Metric with Weldon	39
Metric, DualBlank	40
Metric with through-coolant	41
Inch	43

DRILL BLANKS 44

3xD–12xD with through-coolant	45
For micro-drills with through-coolant	47

RODS WITH HELICAL COOLANT HOLES 48

As sintered	
With two coolant holes, $\leq 22^\circ$	49
With two coolant holes, $23^\circ - 49^\circ$	50
With two coolant holes – extra-long, $23^\circ - 49^\circ$	53
With two coolant holes, $\geq 50^\circ$	54
With three coolant holes	55
With four coolant holes	56
Ground	
With two coolant holes, $\leq 22^\circ$	57
With two coolant holes, $23^\circ - 49^\circ$	58
With three coolant holes	59

RODS WITH STRAIGHT COOLANT HOLES 60

As sintered	
With central coolant hole	61
With two coolant holes	63
Ground	
With central coolant hole	66
With two coolant holes	67

BLANKS FOR GUN DRILLS 68

Rods	
Rods with kidney-shaped coolant hole	69
Profiled rods with kidney-shaped coolant hole, 120°	71
Profiled rods with two coolant holes, 115° and 120°	73
Tips	
Profiled tips with two coolant holes, 115°	75

FLAT AND SQUARE STRIPS, BRAZING TIPS 76

Flat strips	77
Square strips	78
Brazing tips to DIN 8011	79

SPECIAL PRODUCTS 82

Available types	83
-----------------	----

PREFORMS 84

Available types	85
Grades: composition and properties	87
Specifications	88

INFORMATION 90

Product information	
Labelling	91
Pitch classification	92
Specifications	
Specification features	93
Solid carbide rods	94
End mill blanks	95
Drill blanks	96
Rods with helical coolant holes	98
Rods with straight coolant holes	100
Flat and square strips	102
Technical information	
Mechanical properties	103
Physical properties	110
Corrosion resistance	112

The CERATIZIT Group

For over **95 years**, CERATIZIT has been a **pioneer** in developing exceptional hard material solutions for machining and wear protection.

The privately owned company, based in Mamer, Luxembourg, develops and manufactures highly specialised cutting tools, indexable inserts and rods made of hard materials as well as wear parts.

The CERATIZIT Group is the **global market leader** in several wear part application areas, and successfully develops new types of carbide, cermet and ceramic grades which are used for instance in the wood, metal and stone working industries.

Facts & figures

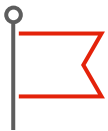

1 headquarters
Mamer, Luxembourg

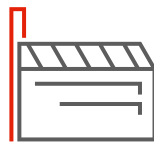

30
production sites



> 50
sales subsidiaries



> 8,000
employees



> 100,000
different products



> 1,000
patents and utility models



> 200
employees in R&D



> 10
innovation awards



30%
of products developed in the last 5 years

CERATIZIT worldwide



Production site

The CERATIZIT centre of excellence for cutting tool products, rods and preforms can be found at the Breitenwang/Reutte site in Austria. CERATIZIT Austria GmbH is certified to ISO 9001 and currently has around 850 employees, making it the second-largest site of the CERATIZIT Group.

From powder preparation to producing rods and preforms and recycling carbide - all production processes are located in Reutte. The CERATIZIT Group continues to focus strongly on this successful production site and in 2013, 2017 and 2018 extended the production surface by 4,000 m², 1,900 m² and 4,500 m² respectively.



Reutte/Austria site





**Highly developed
logistics processes
guarantee
quick and
reliable delivery.**

Supreme availability

A majority of our standard products are available from stock. A well-organised warehouse means that we can respond quickly and reliably to your order, even for bulk quantities. Thanks to our advanced supply chain management, our production capacity is flexible and able to produce a maximum

of quantities, even in a short time frame.

You can order stock products online around the clock at our E-Techstore.



e-techstore.com
Available 24/7 for you

Your benefits:



Live product availability check



Detailed up-to-date technical information and graphic illustrations



Fast delivery: orders up to 6.30 pm will leave our warehouse in Kempten, Germany, on the same day



Reliable delivery: we work only with the best and most reliable service providers in the sector

Cemented carbide

Cemented carbide is a powder metallurgical composite consisting of one or more hard material phases (e.g. tungsten carbide) and a binding material (e.g. cobalt). It is an extremely hard material, characterised by high wear resistance and thermal stability. It is used in various fields that require tools or components to be particularly wear-resistant.

We manage the entire process chain

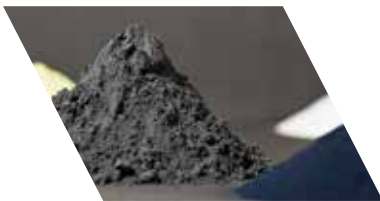

Powder preparation and mixing



Forming / pressing



Sintering



Grinding



Dispatch



Recycling

Cemented carbide

– a composite material with valuable properties

Cemented carbides are composite materials consisting of a hard material and a comparatively soft binder metal, like cobalt (Co). The performance characteristics of cemented carbide are determined by hardness, transverse rupture strength and fracture toughness. With regard to their application, important parameters for the optimisation of these characteristics are the cobalt content and the grain size of the metal binder phase. The tungsten carbide grains have an average size of less than $0.2\mu\text{m}$ up to several micrometres (μm). The cobalt fills the gaps between the carbide grains.

When extremely high toughness is required, the cobalt content can amount to as much as 30%, whereas for maximum wear resistance, the cobalt content is reduced and the grain size decreased to the nanocrystalline range of $< 0.2\mu\text{m}$. CERATIZIT produces far more than 100 different cemented carbide grades particularly for wear parts and cutting tools, thus offering a customised solution for every application.



Carbide production

Carbide production at CERATIZIT started in 1929. Last but not least, thanks to long-standing experience CERATIZIT handles the entire process chain, from the raw material to the dispatching of the finished products to customers. The production process of powder-metallurgical products basically includes the four steps of powder preparation, shaping, sintering and finishing.

Tungsten carbide production

The APT (ammonium para-tungstate) is calcined into tungsten oxide under high temperature. Subsequently the oxide is reduced to tungsten metal in a hydrogen atmosphere. The metal powder is then mixed with carbon and carburised under inert atmosphere at high temperatures. The production parameters are decisive for the WC grain size in the sintered carbide.

APT (ammonium para-tungstate)



Yellow tungsten oxide



Blue tungsten oxide



Powder preparation

The tungsten carbide is intensely mixed with the binder metal cobalt, nickel or iron, various grain growth inhibitors and special alloys as well as materials, which promote compaction, by wet grinding so that a homogeneous suspension is created. Afterwards, the suspension is dried in a spray tower to produce a granulate with good flow characteristics. This granulate represents the basis for all forming processes.

Tungsten



Tungsten carbide



Pressing – shaping – machining

The objective of the forming process is to obtain a near net shape sample. Pressing is normally carried out at room temperature with pressures reaching up to several tons per square centimetre.

There are several ways of pressing blanks:



During isostatic cold pressing the powder is filled into an elastic flexible hose and pressed into a compacted form through high liquid pressure. The powder blocks which are produced in this way can then be processed mechanically. All common machining methods like milling, cutting, drilling or turning may be used.



In uniaxial pressing the pressing tool consists of a die and an upper and a lower punch. The carbide powder is filled into the die and then compacted to create the near net shape geometry of the green compact, which is ejected from the pressing die.



Extrusion pressing is mainly used to produce rectangular bars or cylindrical rods, with or without axial hole(s). A plastifier is added to the powder. The resulting paste is pressed through an extrusion nozzle. Before sintering, the plastifier must be evaporated in special drying furnaces.



Metal Injection Moulding (MIM) is a process used to produce more complex forms which cannot be produced by direct pressing. The paste preparation is similar to the extrusion process.



Sintering



The sintering process converts the blank into a homogeneous and dense cemented carbide with a high level of hardness. The material is sintered at temperatures between 1,300 and 1,500 °C (liquid phase sintering) and sometimes also at high pressure (up to 100 bar). The volume is reduced by up to 50% during this process.



Finishing – grinding



In order to achieve the final requirements of surface finish, tolerances, etc. carbide parts can undergo a series of finishing processes such as grinding, spark erosion and coating.

The most important grinding procedures for carbide rods are centreless grinding and cylindrical grinding. When producing tool blanks, minimum diameter tolerances and optimal surface quality represent an excellent quality characteristic.



Grades: composition and properties

Ultrafine grades

Grade	ISO code*	U.S. code	Binder [m %]	Density [g/cm ³]	Hardness		Transverse rupture strength		KIC** (Shetty) [MPa·m ^{1/2}]
					[HV30]	[HRA]	[MPa]	[psi]	
CTU08L	K10	C-2	4.2	15.05	2200	95.2	3700	536.600	8.4
TSF22	K10 – K20	C-2	8.2	14.55	1930	93.7	4400	638.800	9.2
TSF44	K10 – K20	C-2	12.0	14.10	1730	92.7	4600	667.000	9.8

Submicron grades

Grade	ISO code*	U.S. code	Binder [m %]	Density [g/cm ³]	Hardness		Transverse rupture strength		KIC** (Shetty) [MPa·m ^{1/2}]
					[HV30]	[HRA]	[MPa]	[psi]	
CTS12D	K05 – K10	C-3	6.0	14.80	1820	93.1	3600	522.100	9.3
CTS15D	K10 – K30	C-3	7.5	14.70	1750	92.8	3700	536.000	9.5
CTS18D	K20 – K40	C-2	9.0	14.55	1590	91.9	3650	529.400	10.7
CTS20D	K20 – K40	C-2	10.0	14.38	1600	91.9	4000	580.100	10.4
CTS24Z	K20 – K40	C-2	12.0	14.10	1570	91.7	4000	580.100	11.3
CTS30D	K30 – K40	C-2	15.0	13.84	1400	90.4	4300	623.700	13.2

Fine grades

Grade	ISO code*	U.S. code	Binder [m %]	Density [g/cm ³]	Hardness		Transverse rupture strength		KIC** (Shetty) [MPa·m ^{1/2}]
					[HV30]	[HRA]	[MPa]	[psi]	
CTF12E	K15	C-2	6.0	14.95	1620	92.1	3000	435.100	9.9
CTF25E	K30 – K40	C-2	12.5	14.15	1300	89.5	3500	507.600	15.0

Cermet grade

Grade	ISO code*	U.S. code	Binder [m %]	Density [g/cm ³]	Hardness		Transverse rupture strength		KIC** (Shetty) [MPa·m ^{1/2}]
					[HV30]	[HRA]	[MPa]	[psi]	
CTF28T	K05 – K10	C-2	14.1	6.40	1580	91.8	2000	290.100	8.5

Grain size classification		CERATIZIT code
Average grain size [µm]	Classification	
< 0.2	nano	N
0.2 – < 0.5	ultrafine	U
0.5 – < 0.8	submicron	S
0.8 – < 1.3	fine	F
1.3 – < 2.5	medium	M
2.5 – < 6.0	coarse	C
> 6.0	extra-coarse	E

Comment:

The data in this table are typical material parameters. We reserve the right to modify the data due to technical progress or due to further development within our company.

*) The classification of carbides according to grain size corresponds to the recommendations of the Powder Metallurgy Association.

The standard ISO codes for carbides which were developed for fine to medium grain sizes no longer correspond to today's state of the art. In order to choose the correct grades, only the application data are relevant.

K_{IC}** : The measured critical tension intensity factors (K_{IC}) depend to a high degree on the sample geometry and sample preparation. A direct comparison with parameters which have been determined by means of a different method is therefore not admissible.

Carbide grades for biocompatible tools

in accordance with ISO 10993-5 for the medical and dental industry

The biocompatibility requirement for medical products increases patient safety. For tools that come into short-term direct contact with body tissue, cell tolerance must be guaranteed.

Testing for in-vitro cytotoxicity in accordance with DIN EN ISO 10993-5 was carried out by the accredited testing laboratory Creamedix GmbH. The following carbide grades were successfully tested for their cell tolerance:

- ▲ TSF22 ▲ CTS15D ▲ CTS20D
- ▲ TSF44 ▲ CTS18D ▲ CTS24Z
- ▲ CTS12D



A Tentamus Company

Certified biological testing of the in-vitro cytotoxicity in accordance with

DIN EN ISO 10993-5
by
Creamedix GmbH

Accreditation number
D-PL-19876-01

Ultrafine grades

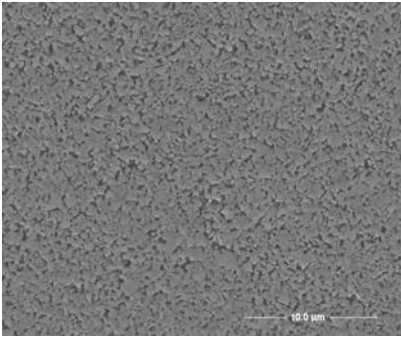

Picture example

CTU08L: carbide grade with a typical grain size of 0.2 μm for the machining of materials with a hardness > 65 HRC. Thanks to the high wear resistance also excellent suitability for abrasive fibre composite materials.

TSF22: ultrafine carbide grade for HSC machining of tempered steels with a hardness of > 60 HRC and abrasive aluminium alloys.

TSF44: ultrafine carbide grade for HSC machining of tempered steels up to 60 HRC, suitable for micro-tools and finishing tools and for a variety of materials.

Submicron grades

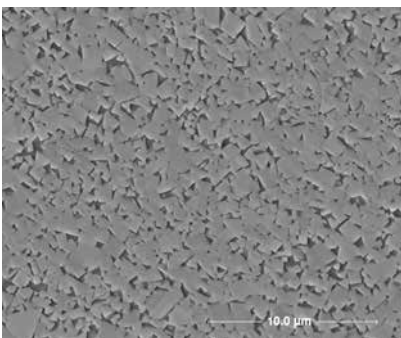

Picture example

CTS12D for machining aluminium alloys, fibre-reinforced plastics (carbon-fibre and glass-fibre reinforced), composite materials, graphite; particularly suitable for diamond coating.

CTS15D for machining grey cast iron, tempered cast iron, non-alloyed steel, non-ferrous metals and plastics.

CTS18D for high-performance machining of steel, stainless steel and the machining of difficult materials.

CTS20D for universal machining of alloyed and non-alloyed steels. Suitable for a variety of cutting operations on different materials thanks to its balanced properties. Improved toughness ensures a low risk of cutting edge breakage.

CTS24Z, the special high-performance grade for the roughing of titanium and heat-resistant alloys. Even higher fracture toughness than CTS18D and CTS20D, with approximately the same hardness.

CTS30D with extremely high fracture toughness for particularly unstable and difficult applications. A good choice when switching from HSS to carbide.

Fine grain grades

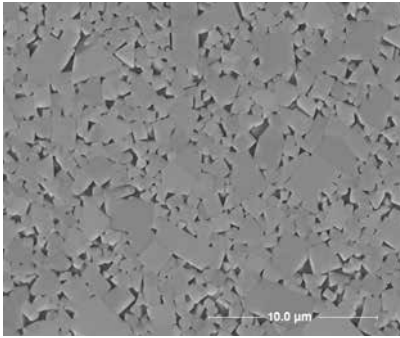

Picture example

CTF12E: for gun drills with an adapted relation between hardness and toughness. Suitable also for diamond-coated solid carbide tools.

CTF25E: for the production of PCD tools and tool shanks. The increased cobalt content and the coarser grain improve brazability while increasing fracture toughness.

Cermet

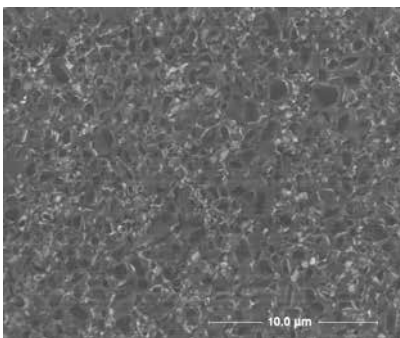

Picture example

CTF28T: particularly for the finish machining of steel. Thanks to high oxidation resistance and low tendency to stick it is particularly suitable for the production of uncoated reamers.

Designation system

RR Sintered rods	
RGM Ground rods, metric	
	C with chamfer
	D DualBlank
	Y with radial coolant exit holes
	W with Weldon shank
RGI Ground rods, inch	
	C with chamfer
00 30 40 Helix angle of coolant hole rods	R coolant hole rods, as sintered
	G coolant hole rods, ground
	B drill blanks
GD Blanks for gun drills	RK round rods with kidney-shaped coolant holes
	VK profiled rods with kidney-shaped coolant holes
	V2 profiled rods with two coolant holes
	V2P profiled tips with two coolant holes
FR Flat strips	
SR Square strips	

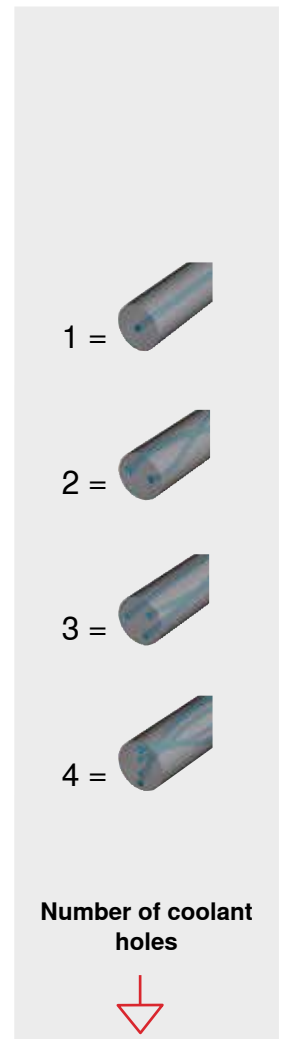

30

G B

2

Outside diameter
[1/100 mm]

Thickness
[1/100 mm]

Diameter of the coolant holes
[mm]

Rod length
[mm]

Diameter tolerance

1000/4,8/1,3/54,4-104 CTS20D h5

Pitch circle of the coolant holes
[mm]

Height
[mm]

Nominal pitch of the coolant holes
[mm]

Grade

Stock programme at a glance

The product map below provides you with a quick overview of the grades and rods which are available in stock. Other products are available upon request.

		Ultra-fine grades			Submicron grades				Fine grades	Cermet	starting page
		CTU08L	TSF22	TSF44	CTS12D	CTS15D	CTS18D	CTS20D	CTS24Z	CTF12E	
Solid carbide rods, as sintered	RR										25
	Solid carbide rods, ground, metric	RGM									29
	Solid carbide rods, inch	RGI									32
End mill blanks, metric	RGMC										35
	End mill blanks with Weldon shank, metric	RGMCW									39
	DualBlank end mill blanks, metric	RGMCD									40
	End mill blanks with through-coolant, metric	RGMCY									41
	End mill blanks, inch	RGIC									43
Drill blanks with through-coolant	..GB2										45
	Drill blanks for micro-drills with through-coolant	..G2									47
Rods, as sintered, with two helical coolant holes	..R2										49
	Rods, as sintered, with three helical coolant holes	..R3									55
	Rods, as sintered, with four helical coolant holes	..R4									56
	Rods, ground, with two helical coolant holes	..G2									57
	Rods, ground, with three helical coolant holes	..G3									59
Rods, as sintered, with central coolant hole	00R1										61
	Rods, as sintered, with two straight coolant holes	00R2									63
	Rods, ground, with central coolant hole	00G1									66
	Rods, ground, with two straight coolant holes	00G2									67
Rods for gun drills with kidney-shaped coolant holes	GDRK										69
	Profiled rods for gun drills with kidney-shaped coolant holes	GDVK									71
	Profiled rods for gun drills with two coolant holes	GDV2									73
	Profiled tips for gun drills with two coolant holes	GDV2P									75
Flat and square strips	FR and SR										77
	Brazing tips to DIN 8011	DIN 8011									79



Solid carbide rods

A comprehensive standard range of sintered and ground solid carbide rods in various dimensions is available from stock. Furthermore, you can choose from carbide grades with the most varied characteristics for every application area: from ultrafine grades for the machining of superhard materials, by way of submicron grades for universal application to our cermet grade for the finish machining of ferrous materials.

Of course we can also produce carbide rods in other dimensions and grades to order – simply get in touch with your contact person at CERATIZIT.

Detailed technical data for our solid carbide rods can be found in the 'Information' section.



As sintered

Ultrafine grades

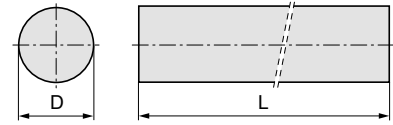

D [mm]	L [mm]	Type, description	Dia. tol. [mm]	CTU08L	TSF22	TSF44
3.25	330	RR 0325-330	-0/+0.20	●	●	●
4.20	330	RR 0420-330	-0/+0.20	●	●	●
5.20	330	RR 0520-330	-0/+0.25	●	●	●
6.20	330	RR 0620-330	-0/+0.25	●	●	●
8.20	330	RR 0820-330	-0/+0.30	●	●	●
10.20	330	RR 1020-330	-0/+0.30	●	●	●
12.20	330	RR 1220-330	-0/+0.30	●	●	●
14.20	330	RR 1420-330	-0/+0.30		●	●
16.20	330	RR 1620-330	-0/+0.45		●	●
18.20	330	RR 1820-330	-0/+0.45		●	○
20.20	330	RR 2020-330	-0/+0.45		●	●
25.20	330	RR 2520-330	-0/+0.65		●	●
32.20	330	RR 3220-330	-0/+0.65			●

As sintered

Submicron grades

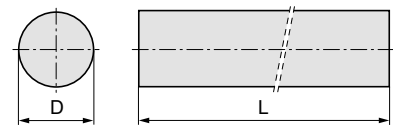

D [mm]	L [mm]	Type, description	Dia. tol. [mm]	CTS12D	CTS15D	CTS18D	CTS20D	CTS24Z	CTS30D
1.15	330	RR 0115-330	-0/+0.15				●		
1.65	330	RR 0165-330	-0/+0.15	●			●		
1.80	330	RR 0180-330	-0/+0.15				●		
2.20	330	RR 0220-330	-0/+0.20	●			●		
2.70	330	RR 0270-330	-0/+0.20				●		
3.25	330	RR 0325-330	-0/+0.20	●	●	●	●	●	
3.70	330	RR 0370-330	-0/+0.20				●		



○ limited stock ● stock item ▲ new stock item Other grades and dimensions upon request

As sintered

Submicron grades

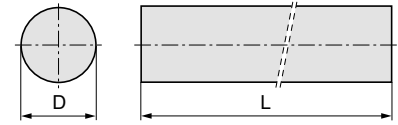

D [mm]	L [mm]	Type, description	Dia. tol. [mm]	CTS12D	CTS15D	CTS18D	CTS20D	CTS24Z	CTS30D
4.20	330	RR 0420-330	-0/+0.20	●	●	●	●	●	
4.70	330	RR 0470-330	-0/+0.20				●		
5.20	330	RR 0520-330	-0/+0.25	●	●		●		
5.70	330	RR 0570-330	-0/+0.25				●		
6.20	330	RR 0620-330	-0/+0.25	●	●	●	●	●	●
6.55	330	RR 0655-330	-0/+0.25				●		
6.70	330	RR 0670-330	-0/+0.25		○		●		
7.20	330	RR 0720-330	-0/+0.30				●		
7.70	330	RR 0770-330	-0/+0.30				●		
8.20	330	RR 0820-330	-0/+0.30	●	●	●	●	●	●
8.70	330	RR 0870-330	-0/+0.30				●		
9.20	330	RR 0920-330	-0/+0.30				●		
9.70	330	RR 0970-330	-0/+0.30				●		
10.20	330	RR 1020-330	-0/+0.30	●	●	●	●	●	●
10.70	330	RR 1070-330	-0/+0.30				●		
11.20	330	RR 1120-330	-0/+0.30				●		
11.70	330	RR 1170-330	-0/+0.30				●		
12.20	330	RR 1220-330	-0/+0.30	●	●	●	●	●	●
12.70	330	RR 1270-330	-0/+0.30		●		●		
13.00	330	RR 1300-330	-0/+0.30				○		
13.20	330	RR 1320-330	-0/+0.30				●		
14.20	330	RR 1420-330	-0/+0.30	●	●	●	●	●	
14.70	330	RR 1470-330	-0/+0.30				●		
15.20	330	RR 1520-330	-0/+0.30				●		
16.20	330	RR 1620-330	-0/+0.45	●	●	●	●	●	●
17.20	330	RR 1720-330	-0/+0.45				●		
18.20	330	RR 1820-330	-0/+0.45	●	●		●	●	
19.20	330	RR 1920-330	-0/+0.45				●		
20.20	330	RR 2020-330	-0/+0.45	●	●	●	●	●	●
21.20	330	RR 2120-330	-0/+0.55				●		
22.20	330	RR 2220-330	-0/+0.55				●		



○ limited stock ● stock item ▲ new stock item Other grades and dimensions upon request

As sintered

Submicron grades



D [mm]	L [mm]	Type, description	Dia. tol. [mm]	CTS12D	CTS15D	CTS18D	CTS20D	CTS24Z	CTS30D
23.20	330	RR 2320-330	-0/+0.55				●		
24.20	330	RR 2420-330	-0/+0.55				●		
25.20	330	RR 2520-330	-0/+0.65		●	●	●	●	○
25.80	330	RR 2580-330	-0/+0.65				○		
26.20	330	RR 2620-330	-0/+0.65				●		
28.20	330	RR 2820-330	-0/+0.65				●		
30.20	330	RR 3020-330	-0/+0.65				●		
32.20	330	RR 3220-330	-0/+0.65			○	●		
34.20	330	RR 3420-330	-0/+0.65				●		
36.20	330	RR 3620-330	-0/+0.65				●		
38.20	330	RR 3820-330	-0/+0.70				○		
40.20	330	RR 4020-330	-0/+0.70				●		
42.20	330	RR 4220-330	-0/+0.70				●		
46.20	330	RR 4620-330	-0/+0.70				●		

As sintered

Fine grades



D [mm]	L [mm]	Type, description	Dia. tol. [mm]	CTF12E
3.25	330	RR 0325-330	-0/+0.20	●
6.20	330	RR 0420-330	-0/+0.20	●
5.20	330	RR 0520-330	-0/+0.25	●
6.20	330	RR 0620-330	-0/+0.25	●
8.20	330	RR 0820-330	-0/+0.30	●
10.20	330	RR 1020-330	-0/+0.30	●



○ limited stock ● stock item ▲ new stock item Other grades and dimensions upon request

As sintered

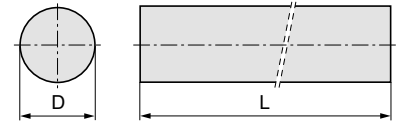
Fine grades

D [mm]	L [mm]	Type, description	Dia. tol. [mm]	CTF12E
12.20	330	RR 1220-330	-0/+0.30	●
14.20	330	RR 1420-330	-0/+0.30	○
16.20	330	RR 1620-330	-0/+0.45	●
18.20	330	RR 1820-330	-0/+0.45	○

As sintered

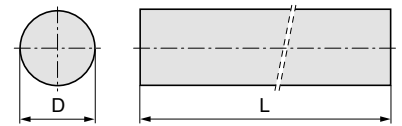
Cermet

D [mm]	L [mm]	Type, description	Dia. tol. [mm]	CTF28T
3.40	330	RR 0340-330	-0/+0.20	●
4.40	330	RR 0440-330	-0/+0.20	●
6.40	330	RR 0640-330	-0/+0.25	●
8.40	330	RR 0840-330	-0/+0.30	●
10.40	330	RR 1040-330	-0/+0.30	●
12.40	330	RR 1240-330	-0/+0.30	●
14.40	300	RR 1440-330	-0/+0.30	▲
16.40	330	RR 1640-330	-0/+0.45	▲
20.40	330	RR 2040-330	-0/+0.45	▲

○ limited stock ● stock item ▲ new stock item Other grades and dimensions upon request

Ground, metric
Ultrafine grades

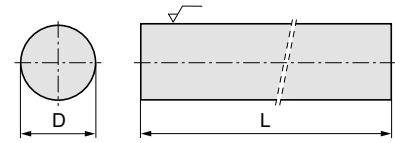

D [mm]	L [mm]	Type, description	Dia. tol.		TSF22	TSF44
			[mm]	ISO 286		
2.00	330	RGM 0200-330	+0/-0.004	h5		●
3.00	330	RGM 0300-330	+0/-0.004	h5	●	●
4.00	330	RGM 0400-330	+0/-0.005	h5	●	●
5.00	330	RGM 0500-330	+0/-0.005	h5	●	●
6.00	330	RGM 0600-330	+0/-0.005	h5	●	●
8.00	330	RGM 0800-330	+0/-0.006	h5	●	●
10.00	330	RGM 1000-330	+0/-0.006	h5	●	●
12.00	330	RGM 1200-330	+0/-0.008	h5	●	●
14.00	330	RGM 1400-330	+0/-0.008	h5	○	●
16.00	330	RGM 1600-330	+0/-0.008	h5	●	●
20.00	330	RGM 2000-330	+0/-0.009	h5	●	●
25.00	330	RGM 2500-330	+0/-0.009	h5	●	●

Ground, metric
Submicron grades

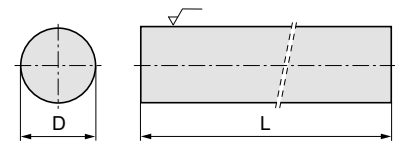

D [mm]	L [mm]	Type, description	Dia. tol.		CTS12D	CTS15D	CTS18D	CTS20D	CTS24Z	CTS30D
			[mm]	ISO 286						
1.00	330	RGM 0100-330	+0/-0.006	h6				●		
1.50	330	RGM 0150-330	+0/-0.006	h6				●		
2.00	330	RGM 0200-330	+0/-0.006	h6				●		
2.50	330	RGM 0250-330	+0/-0.006	h6		●		●		
3.00	330	RGM 0300-330	+0/-0.006	h6	●			●		
3.50	330	RGM 0350-330	+0/-0.008	h6				●		
4.00	330	RGM 0400-330	+0/-0.008	h6	●			●		

○ limited stock ● stock item ▲ new stock item Other grades and dimensions upon request

Ground, metric

Submicron grades

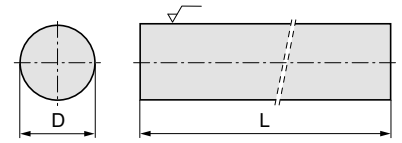

D [mm]	L [mm]	Type, description	Dia. tol.		CTS12D	CTS15D	CTS18D	CTS20D	CTS24Z	CTS30D
			[mm]	ISO 286						
4.50	330	RGM 0450-330	+0/-0.008	h6				●		
5.00	330	RGM 0500-330	+0/-0.008	h6				●		
5.50	330	RGM 0550-330	+0/-0.008	h6				●		
6.00	330	RGM 0600-330	+0/-0.008	h6	●	●	●	●	●	○
6.50	330	RGM 0650-330	+0/-0.009	h6				●		
7.00	330	RGM 0700-330	+0/-0.009	h6				●		
7.50	330	RGM 0750-330	+0/-0.009	h6				●		
8.00	330	RGM 0800-330	+0/-0.009	h6	●	●	●	●	●	○
8.50	330	RGM 0850-330	+0/-0.009	h6				●		
9.00	330	RGM 0900-330	+0/-0.009	h6				●		
9.50	330	RGM 0950-330	+0/-0.009	h6				●		
10.00	330	RGM 1000-330	+0/-0.009	h6	●	●	●	●	●	○
11.00	330	RGM 1100-330	+0/-0.011	h6				●		
12.00	330	RGM 1200-330	+0/-0.011	h6	●	●	●	●	●	○
13.00	330	RGM 1300-330	+0/-0.011	h6				●		
14.00	330	RGM 1400-330	+0/-0.011	h6	●			●		
15.00	330	RGM 1500-330	+0/-0.011	h6				●		
16.00	330	RGM 1600-330	+0/-0.011	h6	●	●	●	●	●	○
18.00	330	RGM 1800-330	+0/-0.011	h6		●		●		
19.00	330	RGM 1900-330	+0/-0.013	h6				●		
20.00	330	RGM 2000-330	+0/-0.013	h6	●	●	●	●	●	○
22.00	330	RGM 2200-330	+0/-0.013	h6				●		
24.00	330	RGM 2400-330	+0/-0.013	h6				●		
25.00	330	RGM 2500-330	+0/-0.013	h6			●	●	●	○
28.00	330	RGM 2800-330	+0/-0.013	h6				●		
30.00	330	RGM 3000-330	+0/-0.013	h6				●		
32.00	330	RGM 3200-330	+0/-0.016	h6			●	●		
38.00	330	RGM 3800-330	+0/-0.016	h6				○		
40.00	330	RGM 4000-330	+0/-0.016	h6				●		

○ limited stock ● stock item ▲ new stock item Other grades and dimensions upon request

Ground, metric
Fine grades

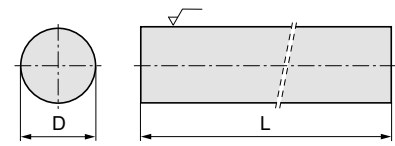

D [mm]	L [mm]	Type, description	Dia. tol.		CTF12E
			[mm]	ISO 286	
3.00	330	RGM 0300-330	+0/-0.004	h6	○
4.00	330	RGM 0400-330	+0/-0.008	h6	●
6.00	330	RGM 0600-330	+0/-0.008	h6	●
8.00	330	RGM 0800-330	+0/-0.009	h6	●
10.00	330	RGM 1000-330	+0/-0.009	h6	●
12.00	330	RGM 1200-330	+0/-0.011	h6	●
14.00	330	RGM 1400-330	+0/-0.011	h6	○
16.00	330	RGM 1600-330	+0/-0.011	h6	○

Ground, metric
Cermet

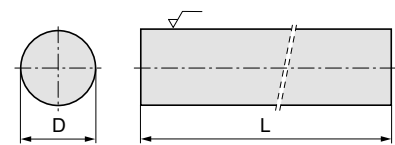

D [mm]	L [mm]	Type, description	Dia. tol.		CTF28T
			[mm]	ISO 286	
3.00	330	RGM 0300-330	+0/-0.004	h6	○
4.00	330	RGM 0400-330	+0/-0.008	h6	●
6.00	330	RGM 0600-330	+0/-0.008	h6	●
8.00	330	RGM 0800-330	+0/-0.009	h6	●
10.00	330	RGM 1000-330	+0/-0.009	h6	●
12.00	330	RGM 1200-330	+0/-0.011	h6	○
14.00	330	RGM 1400-330	+0/-0.011	h6	▲
16.00	330	RGM 1600-330	+0/-0.011	h6	▲
20.00	330	RGM 2000-330	+0/-0.013	h6	▲

○ limited stock ● stock item ▲ new stock item Other grades and dimensions upon request

Ground, inch

Submicron grades

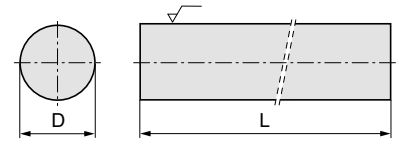

D [inch]	L [inch]	Type, description	Dia. tol.		CTS20D
			[mm]	ISO 286	
1/8	13.000	RGI 1/8-13	+0/-0.008	h6	●
3/16	13.000	RGI 3/16-13	+0/-0.008	h6	●
1/4	13.000	RGI 1/4-13	+0/-0.009	h6	●
5/16	13.000	RGI 5/16-13	+0/-0.009	h6	●
3/8	13.000	RGI 3/8-13	+0/-0.009	h6	●
7/16	13.000	RGI 7/16-13	+0/-0.011	h6	●
1/2	13.000	RGI 1/2-13	+0/-0.011	h6	●
5/8	13.000	RGI 5/8-13	+0/-0.011	h6	●
3/4	13.000	RGI 3/4-13	+0/-0.013	h6	●
1	13.000	RGI 1-13	+0/-0.013	h6	●

○ limited stock ● stock item ▲ new stock item Other grades and dimensions upon request



End mill blanks

In addition to DIN dimensions, we can also supply our high-precision end mill blanks in extra-long sizes. End mill blanks in the most popular inch dimensions have now been added to the range. Whether in standard execution, with Weldon shanks, internal cooling or as a DualBlank, you can be sure of finding the product you need.

Our end mill blanks are now also available in the new high-performance grade CTS24Z for the machining of difficult materials like titanium or Inconel. Having virtually the same hardness, CTS24Z is even tougher than our proven CTS18D and CTS20D grades. This extreme toughness offers maximum protection against breakage and ensures consistent performance of your tools.

Of course we can also produce carbide rods in other dimensions and grades to order – just get in touch with your contact person at CERATIZIT.

Detailed technical data for our end mill blanks can be found in the 'Information' section.



Metric

Ultrafine grades

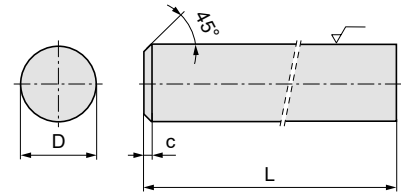

D [mm]	L [mm]	Type, description	Dia. tol.		c [mm]	DIN 6527	CTU08L	TSF22	TSF44
			[mm]	ISO 286					
3.00	39	RGMC 0300-039	+0/-0.004	h5	0.30	x	○	●	●
3.00	40	RGMC 0300-040	+0/-0.004	h5	0.30			●	
3.00	50	RGMC 0300-050	+0/-0.004	h5	0.30			●	●
3.00	60	RGMC 0300-060	+0/-0.004	h5	0.30			●	
4.00	51	RGMC 0400-051	+0/-0.004	h5	0.40	x	●	●	●
4.00	60	RGMC 0400-060	+0/-0.005	h5	0.40			●	
4.00	75	RGMC 0400-075	+0/-0.005	h5	0.40			●	
5.00	51	RGMC 0500-051	+0/-0.005	h5	0.40	x			○
6.00	51	RGMC 0600-051	+0/-0.005	h5	0.40	x		●	●
6.00	58	RGMC 0600-058	+0/-0.005	h5	0.40	x	●	●	●
6.00	60	RGMC 0600-060	+0/-0.005	h5	0.40			●	
6.00	65	RGMC 0600-065	+0/-0.005	h5	0.40			●	
6.00	70	RGMC 0600-070	+0/-0.005	h5	0.40			●	
6.00	75	RGMC 0600-075	+0/-0.005	h5	0.40			●	
6.00	80	RGMC 0600-080	+0/-0.005	h5	0.40			●	
6.00	100	RGMC 0600-100	+0/-0.005	h5	0.40			●	●
8.00	64	RGMC 0800-064	+0/-0.006	h5	0.60	x	●	●	●
8.00	70	RGMC 0800-070	+0/-0.006	h5	0.60			●	
8.00	75	RGMC 0800-075	+0/-0.006	h5	0.60			●	
8.00	100	RGMC 0800-100	+0/-0.006	h5	0.60			●	●
8.00	120	RGMC 0800-120	+0/-0.006	h5	0.60			●	●
10.00	67	RGMC 1000-067	+0/-0.006	h5	0.80	x			●
10.00	73	RGMC 1000-073	+0/-0.006	h5	0.80	x	●	●	●
10.00	75	RGMC 1000-075	+0/-0.006	h5	0.80			●	
10.00	80	RGMC 1000-080	+0/-0.006	h5	0.80			●	
10.00	100	RGMC 1000-100	+0/-0.006	h5	0.80			●	●
10.00	120	RGMC 1000-120	+0/-0.006	h5	0.80			●	●
12.00	84	RGMC 1200-084	+0/-0.008	h5	0.80	x		●	●
12.00	100	RGMC 1200-100	+0/-0.008	h5	0.80			●	●
12.00	120	RGMC 1200-120	+0/-0.008	h5	0.80			●	●



○ limited stock ● stock item ▲ new stock item Other grades and dimensions upon request

Metric

Ultrafine grades

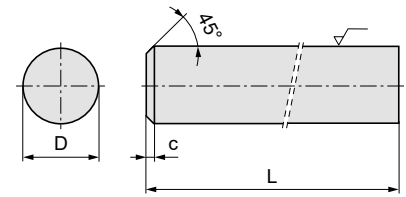

D [mm]	L [mm]	Type, description	Dia. tol.		c [mm]	DIN 6527	CTU08L	TSF22	TSF44
			[mm]	ISO 286					
16.00	93	RGMC 1600-093	+0/-0.008	h5	0.80	x		●	●
16.00	110	RGMC 1600-110	+0/-0.008	h5	0.80			●	
16.00	120	RGMC 1600-120	+0/-0.008	h5	0.80				●
16.00	130	RGMC 1600-130	+0/-0.008	h5	0.80				●
16.00	150	RGMC 1600-150	+0/-0.008	h5	0.80				○
20.00	105	RGMC 2000-105	+0/-0.009	h5	1.00	x			●
20.00	125	RGMC 2000-125	+0/-0.009	h5	1.00			●	●
20.00	150	RGMC 2000-150	+0/-0.009	h5	1.00				●
25.00	125	RGMC 2500-125	+0/-0.009	h5	1.00				○
25.00	150	RGMC 2500-150	+0/-0.009	h5	1.00				○

Metric

Submicron grades

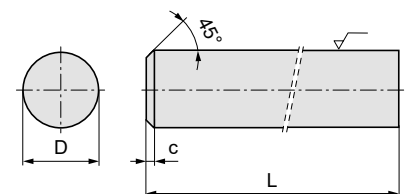

D [mm]	L [mm]	Type, description	Dia. tol.		c [mm]	DIN 6527	CTS18D	CTS20D	CTS24Z
			[mm]	ISO 286					
3.00	39	RGMC 0300-039	+0/-0.006	h6	0.30	x		●	
3.00	40	RGMC 0300-040	+0/-0.004	h5	0.30			●	
3.00	50	RGMC 0300-050	+0/-0.004	h5	0.30			●	
3.00	60	RGMC 0300-060	+0/-0.004	h5	0.30			●	
4.00	51	RGMC 0400-051	+0/-0.008	h6	0.40	x		●	
4.00	60	RGMC 0400-060	+0/-0.005	h5	0.40			●	
4.00	75	RGMC 0400-075	+0/-0.005	h5	0.40			●	
5.00	51	RGMC 0500-051	+0/-0.008	h6	0.40	x		●	
6.00	51	RGMC 0600-051	+0/-0.008	h6	0.40	x		●	

○ limited stock ● stock item ▲ new stock item Other grades and dimensions upon request



Metric

Submicron grades

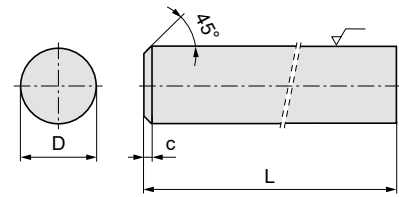

D [mm]	L [mm]	Type, description	Dia. tol. [mm]	ISO 286	c [mm]	DIN 6527	CTS18D	CTS20D	CTS24Z
6.00	55	RGMC 0600-055	+0/-0.008	h6	0.40	x		●	●
6.00	58	RGMC 0600-058	+0/-0.005	h5	0.40	x	●	●	●
6.00	60	RGMC 0600-060	+0/-0.005	h5	0.40			●	
6.00	65	RGMC 0600-065	+0/-0.005	h5	0.40			●	
6.00	70	RGMC 0600-070	+0/-0.005	h5	0.40			●	
6.00	75	RGMC 0600-075	+0/-0.005	h5	0.40			●	
6.00	80	RGMC 0600-080	+0/-0.005	h5	0.40			●	
6.00	100	RGMC 0600-100	+0/-0.005	h5	0.40			●	
8.00	59	RGMC 0800-059	+0/-0.009	h6	0.60	x		●	●
8.00	64	RGMC 0800-064	+0/-0.009	h6	0.60	x	●	●	●
8.00	70	RGMC 0800-070	+0/-0.006	h5	0.60			●	
8.00	75	RGMC 0800-075	+0/-0.006	h5	0.60			●	
8.00	80	RGMC 0800-080	+0/-0.006	h5	0.60			●	
8.00	100	RGMC 0800-100	+0/-0.006	h5	0.60			●	●
8.00	120	RGMC 0800-120	+0/-0.006	h5	0.60			●	
10.00	67	RGMC 1000-067	+0/-0.009	h6	0.80	x		●	●
10.00	73	RGMC 1000-073	+0/-0.009	h6	0.80	x	●	●	●
10.00	75	RGMC 1000-075	+0/-0.006	h5	0.80			●	
10.00	80	RGMC 1000-080	+0/-0.006	h5	0.80			●	
10.00	90	RGMC 1000-090	+0/-0.006	h5	0.80			●	
10.00	100	RGMC 1000-100	+0/-0.006	h5	0.80			●	●
10.00	120	RGMC 1000-120	+0/-0.006	h5	0.80			●	
12.00	74	RGMC 1200-074	+0/-0.011	h6	0.80	x		●	●
12.00	84	RGMC 1200-084	+0/-0.011	h6	0.80	x	●	●	●
12.00	100	RGMC 1200-100	+0/-0.008	h5	0.80			●	●
12.00	120	RGMC 1200-120	+0/-0.008	h5	0.80			●	
14.00	76	RGMC 1400-076	+0/-0.011	h6	0.80	x		●	
14.00	84	RGMC 1400-084	+0/-0.011	h6	0.80	x		●	●
16.00	83	RGMC 1600-083	+0/-0.011	h6	0.80	x		●	
16.00	93	RGMC 1600-093	+0/-0.011	h6	0.80	x	●	●	●



○ limited stock ● stock item ▲ new stock item Other grades and dimensions upon request

Metric

Submicron grades

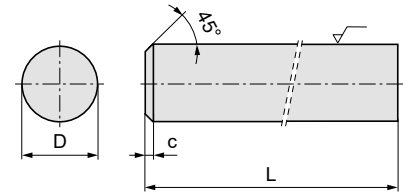

D [mm]	L [mm]	Type, description	Dia. tol.		c [mm]	DIN 6527	CTS18D	CTS20D	CTS24Z
			[mm]	ISO 286					
16.00	110	RGMC 1600-110	+0/-0.008	h5	0.80			●	
16.00	120	RGMC 1600-120	+0/-0.008	h5	0.80			●	●
16.00	130	RGMC 1600-130	+0/-0.008	h5	0.80			●	
16.00	150	RGMC 1600-150	+0/-0.008	h5	0.80			●	
18.00	93	RGMC 1800-093	+0/-0.011	h6	1.00	x		●	
20.00	93	RGMC 2000-093	+0/-0.013	h6	1.00	x		●	
20.00	105	RGMC 2000-105	+0/-0.009	h5	1.00	x	●	●	●
20.00	125	RGMC 2000-125	+0/-0.009	h5	1.00			●	●
20.00	150	RGMC 2000-150	+0/-0.009	h5	1.00			●	
25.00	125	RGMC 2500-125	+0/-0.009	h5	1.00			●	
25.00	150	RGMC 2500-150	+0/-0.009	h5	1.00			●	

○ limited stock ● stock item ▲ new stock item Other grades and dimensions upon request

Metric with Weldon
Submicron grades

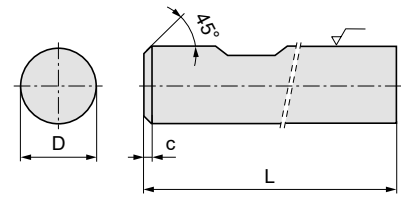

D [mm]	L [mm]	Type, description	Dia. tol.		c [mm]	DIN 6527	CTS20D
			[mm]	ISO 286			
6.00	51	RGMCW 0600-051	+0/-0.008	h6	0.40	x	●
6.00	55	RGMCW 0600-055	+0/-0.008	h6	0.40	x	○
6.00	58	RGMCW 0600-058	+0/-0.008	h6	0.40	x	●
8.00	64	RGMCW 0800-064	+0/-0.009	h6	0.60	x	●
10.00	67	RGMCW 1000-067	+0/-0.009	h6	0.80	x	●
10.00	73	RGMCW 1000-073	+0/-0.009	h6	0.80	x	●
12.00	74	RGMCW 1200-074	+0/-0.011	h6	0.80	x	●
12.00	84	RGMCW 1200-084	+0/-0.011	h6	0.80	x	●
16.00	93	RGMCW 1600-093	+0/-0.011	h6	0.80	x	●
20.00	93	RGMCW 2000-093	+0/-0.013	h6	1.00	x	○
20.00	105	RGMCW 2000-105	+0/-0.013	h6	1.00	x	●

○ limited stock ● stock item ▲ new stock item Other grades and dimensions upon request

Metric, DualBlank

Submicron grades

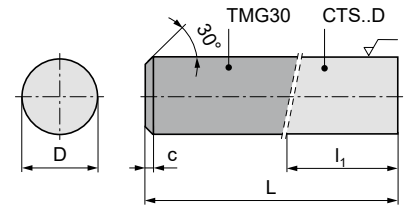

D [mm]	L [mm]	Type, description	Dia. tol.		l ₁ [mm]	c [mm]	DIN 6527	CTS20D	CTS18D
			[mm]	ISO 286					
6.00	58	RGMCD 0600-058	+0/-0.008	h6	26	0.50	x	●	●
8.00	64	RGMCD 0800-064	+0/-0.009	h6	29	0.70	x	●	●
10.00	73	RGMCD 1000-073	+0/-0.009	h6	33	0.90	x	●	●
12.00	84	RGMCD 1200-084	+0/-0.011	h6	38	0.90	x	●	●
16.00	93	RGMCD 1600-093	+0/-0.011	h6	41	0.90	x	●	●
20.00	105	RGMCD 2000-105	+0/-0.013	h6	46	1.10	x	●	●



DualBlank rods

A combination of a high-performing Premium grade in the cutting edge area, with a shank made of an economical recycled grade.

- ▲ The high-performance grade in the cutting edge area guarantees maximum performance in metal cutting
- ▲ Absolutely homogeneous and resistant to fracture where the two materials are joined
- ▲ Optimised price-performance ratio
- ▲ Produced with less impact of the environment

Metric with through-coolant, 2x 180°

Submicron grades

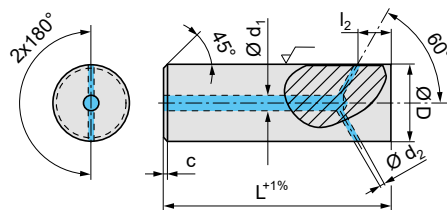

D [mm]	L [mm]	Type, description	Dia. tol. [mm]	ISO 286	d ₁ [mm]	d ₂ [mm]	l ₂ [mm]	c [mm]	CTS20D
6.00	58	RGMCY2 0600-058	+0/-0.008	h6	1.20	0.80	3.00	0.40	○
8.00	64	RGMCY2 0800-064	+0/-0.009	h6	1.60	1.10	4.00	0.60	○
10.00	73	RGMCY2 1000-073	+0/-0.009	h6	2.00	1.40	5.00	0.80	○
12.00	84	RGMCY2 1200-084	+0/-0.011	h6	2.20	1.60	6.00	0.80	○
14.00	84	RGMCY2 1400-084	+0/-0.011	h6	2.40	1.70	7.00	0.80	○
16.00	93	RGMCY2 1600-093	+0/-0.011	h6	2.60	1.90	8.00	0.80	○
18.00	93	RGMCY2 1800-093	+0/-0.011	h6	2.80	2.00	9.00	1.00	○
20.00	105	RGMCY2 2000-105	+0/-0.013	h6	3.00	2.10	10.00	1.00	○
25.00	125	RGMCY2 2500-125	+0/-0.013	h6	3.20	2.30	12.50	1.00	○

Metric with through-coolant, 3x 120°

Submicron grades

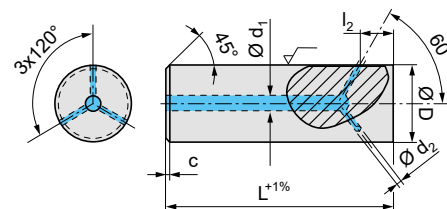

D [mm]	L [mm]	Type, description	Dia. tol. [mm]	ISO 286	d ₁ [mm]	d ₂ [mm]	l ₂ [mm]	c [mm]	CTS20D
6.00	58	RGMCY3 0600-058	+0/-0.008	h6	1.20	0.70	3.00	0.40	●
8.00	64	RGMCY3 0800-064	+0/-0.009	h6	1.60	0.90	4.00	0.60	●
10.00	73	RGMCY3 1000-073	+0/-0.009	h6	2.00	1.20	5.00	0.80	●
12.00	84	RGMCY3 1200-084	+0/-0.011	h6	2.20	1.30	6.00	0.80	●
14.00	84	RGMCY3 1400-084	+0/-0.011	h6	2.40	1.40	7.00	0.80	●
16.00	93	RGMCY3 1600-093	+0/-0.011	h6	2.60	1.50	8.00	0.80	●
18.00	93	RGMCY3 1800-093	+0/-0.011	h6	2.80	1.60	9.00	1.00	●
20.00	105	RGMCY3 2000-105	+0/-0.013	h6	3.00	1.70	10.00	1.00	●
25.00	125	RGMCY3 2500-125	+0/-0.013	h6	3.20	1.80	12.50	1.00	●

○ limited stock ● stock item ▲ new stock item Other grades and dimensions upon request

Metric with through-coolant, 4x 90°

Submicron grades

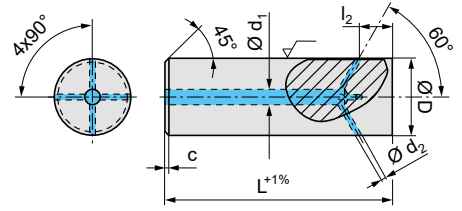

D [mm]	L [mm]	Type, description	Dia. tol. [mm]	ISO 286	d ₁ [mm]	d ₂ [mm]	l ₂ [mm]	c [mm]	CTS20D
6.00	58	RGMCY4 0600-058	+0/-0.008	h6	1.20	0.60	3.00	0.40	●
8.00	64	RGMCY4 0800-064	+0/-0.009	h6	1.60	0.80	4.00	0.60	●
10.00	73	RGMCY4 1000-073	+0/-0.009	h6	2.00	1.00	5.00	0.80	●
12.00	84	RGMCY4 1200-084	+0/-0.011	h6	2.20	1.10	6.00	0.80	●
14.00	84	RGMCY4 1400-084	+0/-0.011	h6	2.40	1.20	7.00	0.80	●
16.00	93	RGMCY4 1600-093	+0/-0.011	h6	2.60	1.30	8.00	0.80	●
18.00	93	RGMCY4 1800-093	+0/-0.011	h6	2.80	1.40	9.00	1.00	●
20.00	105	RGMCY4 2000-105	+0/-0.013	h6	3.00	1.50	10.00	1.00	●
25.00	125	RGMCY4 2500-125	+0/-0.013	h6	3.20	1.60	12.50	1.00	●

Metric with through-coolant, 5x 72°

Submicron grades

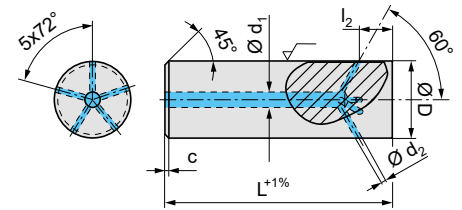

D [mm]	L [mm]	Type, description	Dia. tol. [mm]	ISO 286	d ₁ [mm]	d ₂ [mm]	l ₂ [mm]	c [mm]	CTS20D
6.00	58	RGMCY5 0600-058	+0/-0.008	h6	1.20	0.50	3.00	0.40	○
8.00	64	RGMCY5 0800-064	+0/-0.009	h6	1.60	0.70	4.00	0.60	○
10.00	73	RGMCY5 1000-073	+0/-0.009	h6	2.00	0.90	5.00	0.80	○
12.00	84	RGMCY5 1200-084	+0/-0.011	h6	2.20	1.00	6.00	0.80	○
14.00	84	RGMCY5 1400-084	+0/-0.011	h6	2.40	1.10	7.00	0.80	○
16.00	93	RGMCY5 1600-093	+0/-0.011	h6	2.60	1.20	8.00	0.80	○
18.00	93	RGMCY5 1800-093	+0/-0.011	h6	2.80	1.30	9.00	1.00	○
20.00	105	RGMCY5 2000-105	+0/-0.013	h6	3.00	1.40	10.00	1.00	○
25.00	125	RGMCY5 2500-125	+0/-0.013	h6	3.20	1.50	12.50	1.00	○

○ limited stock ● stock item ▲ new stock item Other grades and dimensions upon request

Inch

Submicron grades

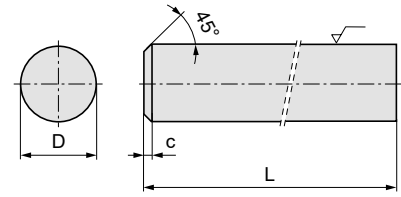

D [inch]	L [inch]	Type, description	Dia. tol. [mm]	ISO 286	c [mm]	CTS20D
1/8	1.500	RGIC 1/8 - 1.50	+0/-0.008	h6	0.25	●
3/16	2.000	RGIC 3/16 - 2.00	+0/-0.008	h6	0.40	●
1/4	2.000	RGIC 1/4 - 2.00	+0/-0.009	h6	0.40	●
1/4	3.000	RGIC 1/4 - 3.00	+0/-0.009	h6	0.40	●
5/16	2.500	RGIC 5/16 - 2.50	+0/-0.009	h6	0.40	●
3/8	2.500	RGIC 3/8 - 2.50	+0/-0.009	h6	0.40	●
3/8	3.000	RGIC 3/8 - 3.00	+0/-0.009	h6	0.40	●
1/2	3.000	RGIC 1/2 - 3.00	+0/-0.011	h6	0.80	●
1/2	4.000	RGIC 1/2 - 4.00	+0/-0.011	h6	0.80	●
5/8	3.500	RGIC 5/8 - 3.50	+0/-0.011	h6	0.80	●
3/4	4.000	RGIC 3/4 - 4.00	+0/-0.013	h6	0.80	●
1	4.000	RGIC 1 - 4.00	+0/-0.013	h6	0.80	●
1	6.000	RGIC 1 - 6.00	+0/-0.013	h6	0.80	●

○ limited stock ● stock item ▲ new stock item Other grades and dimensions upon request

Drill blanks

In addition to their geometrical precision thanks to a special grinding surface, our drill blanks are also notable for the improved pull-out resistance of the tool shank. The shank end corresponds to DIN 69090-3 and therefore complies with the standard for cutting tools which are suitable for MQL.

Of course we can also produce carbide rods in other dimensions and grades to order – just get in touch with your contact person at CERATIZIT.

Detailed technical data for our drill blanks can be found in the 'Information' section.

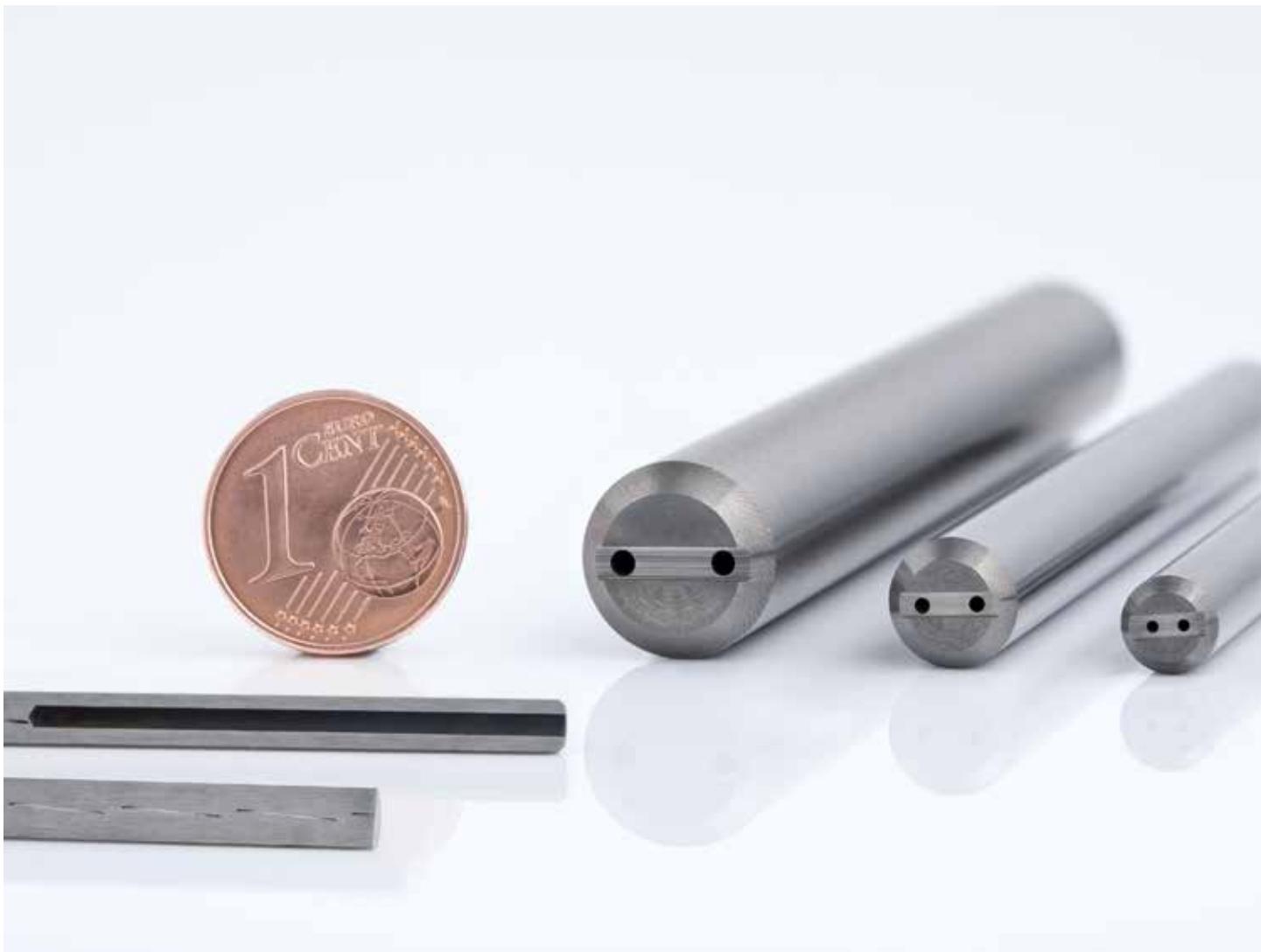

3xD, 5xD with through-coolant

Drill blanks

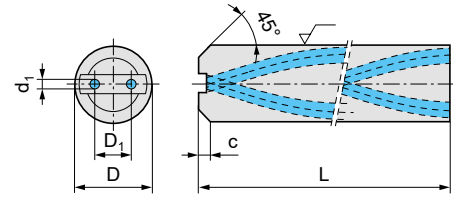

xD factor	D [mm]	L [mm]	Type, description	Dia. tol.		Nominal pitch		c [mm]	D ₁ [mm]	d ₁ [mm]	CTS20D
				[mm]	ISO 286	[mm]	[°]				
3	6.00	63	40GB2 0600/1,9/0,7/22,5-063	+0/-0.005	h5	22.50	40.0	0.95	1.90	0.70	○
3	6.00	63	46GB2 0600/1,6/0,5/18,0-063	+0/-0.005	h5	18.00	46.3	0.95	1.60	0.50	○
3	6.00	67	30GB2 0600/2,7/0,8/32,7-067	+0/-0.005	h5	32.70	30.0	0.95	2.70	0.80	○
3	6.00	67	33GB2 0600/2,2/0,9/29,0-067	+0/-0.005	h5	29.00	33.0	0.95	2.20	0.90	○
3	8.00	80	30GB2 0800/3,4/1,0/43,5-080	+0/-0.006	h5	43.50	30.0	1.25	3.40	1.00	○
3	10.00	90	30GB2 1000/4,8/1,3/54,4-090	+0/-0.006	h5	54.40	30.0	1.35	4.80	1.30	○
3	12.00	103	30GB2 1200/6,3/1,7/65,3-103	+0/-0.008	h5	65.30	30.0	1.75	6.30	1.70	○
3	14.00	108	30GB2 1400/6,7/1,8/76,2-108	+0/-0.008	h5	76.20	30.0	1.95	6.70	1.80	○
3	16.00	116	30GB2 1600/8,0/2,0/87,1-116	+0/-0.008	h5	87.10	30.0	2.45	8.00	2.00	○
3	18.00	124	30GB2 1800/9,0/2,3/98,0-124	+0/-0.008	h5	98.00	30.0	2.75	9.00	2.30	○
3	20.00	132	30GB2 2000/10,0/2,5/108,8-132	+0/-0.009	h5	108.80	30.0	3.25	10.00	2.50	○
5	6.00	67	46GB2 0600/1,6/0,5/18,0-067	+0/-0.005	h5	18.00	46.3	0.95	1.60	0.50	●
5	6.00	67	40GB2 0600/1,9/0,7/22,5-067	+0/-0.005	h5	22.50	40.0	0.95	1.90	0.70	●
5	6.00	75	33GB2 0600/2,2/0,9/29,0-075	+0/-0.005	h5	29.00	33.0	0.95	2.20	0.90	●
5	6.00	75	40GB2 0600/1,9/0,7/22,5-075	+0/-0.005	h5	22.50	40.0	0.95	1.90	0.70	●
5	6.00	83	30GB2 0600/2,7/0,8/32,7-083	+0/-0.005	h5	32.70	30.0	0.95	2.70	0.80	●
5	8.00	92	30GB2 0800/3,4/1,0/43,5-092	+0/-0.006	h5	43.50	30.0	1.25	3.40	1.00	●
5	10.00	104	30GB2 1000/4,8/1,3/54,4-104	+0/-0.006	h5	54.40	30.0	1.35	4.80	1.30	●
5	12.00	119	30GB2 1200/6,3/1,7/65,3-119	+0/-0.008	h5	65.30	30.0	1.75	6.30	1.70	●
5	14.00	125	30GB2 1400/6,7/1,8/76,2-125	+0/-0.008	h5	76.20	30.0	1.95	6.70	1.80	●
5	16.00	134	30GB2 1600/8,0/2,0/87,1-134	+0/-0.008	h5	87.10	30.0	2.45	8.00	2.00	●
5	18.00	144	30GB2 1800/9,0/2,3/98,0-144	+0/-0.008	h5	98.00	30.0	2.75	9.00	2.30	●
5	20.00	154	30GB2 2000/10,0/2,5/108,8-154	+0/-0.009	h5	108.80	30.0	3.25	10.00	2.50	○

○ limited stock ● stock item ▲ new stock item Other grades and dimensions upon request

8xD, 12xD with through-coolant

Drill blanks

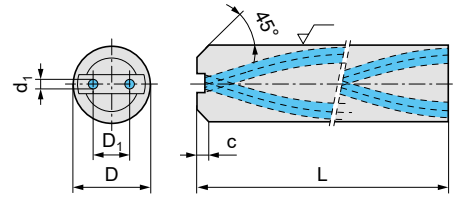

xD factor	D [mm]	L [mm]	Type, description	Dia. tol. [mm]	ISO 286	Nominal pitch [mm]	°	c [mm]	D ₁ [mm]	d ₁ [mm]	CTS20D
8	6.00	73	46GB2 0600/1,6/0,5/18,0-073	+0/-0.005	h5	18.00	46.3	0.95	1.60	0.50	o
8	6.00	73	40GB2 0600/1,9/0,7/22,5-073	+0/-0.005	h5	22.50	40.0	0.95	1.90	0.70	o
8	6.00	82	33GB2 0600/2,2/0,9/29,0-082	+0/-0.005	h5	29.00	33.0	0.95	2.20	0.90	o
8	6.00	82	40GB2 0600/1,9/0,7/22,5-082	+0/-0.005	h5	22.50	40.0	0.95	1.90	0.70	o
8	6.00	96	30GB2 0600/2,7/0,8/32,7-096	+0/-0.005	h5	32.70	30.0	0.95	2.70	0.80	o
8	8.00	115	30GB2 0800/3,4/1,0/43,5-115	+0/-0.006	h5	43.50	30.0	1.25	3.40	1.00	o
8	10.00	143	30GB2 1000/4,8/1,3/54,4-143	+0/-0.006	h5	54.40	30.0	1.35	4.80	1.30	o
8	12.00	163	30GB2 1200/6,3/1,7/65,3-163	+0/-0.008	h5	65.30	30.0	1.75	6.30	1.70	o
8	14.00	179	30GB2 1400/6,7/1,8/76,2-179	+0/-0.008	h5	76.20	30.0	1.95	6.70	1.80	o
8	16.00	204	30GB2 1600/8,0/2,0/87,1-204	+0/-0.008	h5	87.10	30.0	2.45	8.00	2.00	o
8	18.00	223	30GB2 1800/9,0/2,3/98,0-223	+0/-0.008	h5	98.00	30.0	2.75	9.00	2.30	o
8	20.00	244	30GB2 2000/10,0/2,5/108,8-244	+0/-0.009	h5	108.80	30.0	3.25	10.00	2.50	o
12	6.00	93	40GB2 0600/1,9/0,7/22,5-093	+0/-0.005	h5	22.50	40.0	0.95	1.90	0.70	o
12	6.00	93	46GB2 0600/1,6/0,5/18,0-093	+0/-0.005	h5	18.00	46.3	0.95	1.60	0.50	o
12	6.00	103	40GB2 0600/1,9/0,7/22,5-103	+0/-0.005	h5	22.50	40.0	0.95	1.90	0.70	o
12	6.00	103	33GB2 0600/2,2/0,9/29,0-103	+0/-0.005	h5	29.00	33.0	0.95	2.20	0.90	o
12	6.00	117	30GB2 0600/2,7/0,8/32,7-117	+0/-0.005	h5	32.70	30.0	0.95	2.70	0.80	o
12	8.00	147	30GB2 0800/3,4/1,0/43,5-147	+0/-0.006	h5	43.50	30.0	1.25	3.40	1.00	o
12	10.00	163	30GB2 1000/4,8/1,3/54,4-163	+0/-0.006	h5	54.40	30.0	1.35	4.80	1.30	o
12	12.00	205	30GB2 1200/6,3/1,7/65,3-205	+0/-0.008	h5	65.30	30.0	1.75	6.30	1.70	o
12	14.00	231	30GB2 1400/6,7/1,8/76,2-231	+0/-0.008	h5	76.20	30.0	1.95	6.70	1.80	o
12	16.00	261	30GB2 1600/8,0/2,0/87,1-261	+0/-0.008	h5	87.10	30.0	2.45	8.00	2.00	o
12	18.00	286	30GB2 1800/9,0/2,3/98,0-286	+0/-0.008	h5	98.00	30.0	2.75	9.00	2.30	o
12	20.00	311	30GB2 2000/10,0/2,5/108,8-311	+0/-0.009	h5	108.80	30.0	3.25	10.00	2.50	o

o limited stock ● stock item ▲ new stock item Other grades and dimensions upon request

For micro-drills with through-coolant

Blanks for micro-drills

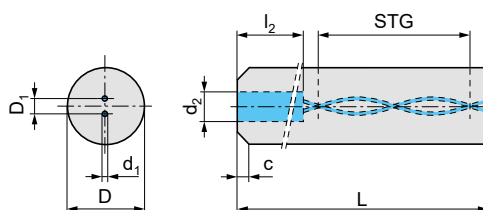

D [mm]	L [mm]	Type, description	Dia. tol.		Nominal pitch		c [mm]	D ₁ [mm]	d ₁ [mm]	d ₂ [mm]	l ₂ [mm]	CTS20D
			[mm]	ISO 286	[mm]	[°]						
3.00	55	71G2 0300/0,29/0,05/3,2-055	+0/-0.004	h5	3.20	71.2	0.20	0.29	0.05	0.70	25	○
3.00	60	67G2 0300/0,37/0,07/4,0-060	+0/-0.004	h5	4.00	67.0	0.20	0.37	0.07	0.90	25	●
3.00	65	62G2 0300/0,47/0,10/5,0-065	+0/-0.004	h5	5.00	62.1	0.20	0.47	0.10	1.20	25	●
3.00	75	58G2 0300/0,60/0,13/6,0-075	+0/-0.004	h5	6.00	57.5	0.20	0.60	0.13	1.50	25	●
3.00	85	53G2 0300/0,75/0,16/7,2-085	+0/-0.004	h5	7.20	52.6	0.20	0.75	0.16	1.70	25	●
3.00	95	46G2 0300/0,90/0,20/9,0-095	+0/-0.004	h5	9.00	46.3	0.20	0.90	0.20			●
3.00	105	42G2 0300/1,05/0,25/10,6-105	+0/-0.004	h5	10.60	41.6	0.20	1.05	0.25			●
3.00	120	37G2 0300/1,25/0,30/12,5-120	+0/-0.004	h5	12.50	37.0	0.20	1.25	0.30			●
3.00	140	33G2 0300/1,50/0,35/14,5-140	+0/-0.004	h5	14.50	33.0	0.20	1.50	0.35			●
4.00	55	76G2 0400/0,29/0,05/3,2-055	+0/-0.005	h5	3.20	75.7	0.30	0.29	0.05	0.70	25	○
4.00	60	72G2 0400/0,37/0,07/4,0-060	+0/-0.005	h5	4.00	72.3	0.30	0.37	0.07	0.90	25	○
4.00	65	68G2 0400/0,47/0,10/5,0-065	+0/-0.005	h5	5.00	68.3	0.30	0.47	0.10	1.20	25	●
4.00	75	64G2 0400/0,60/0,13/6,0-075	+0/-0.005	h5	6.00	64.5	0.30	0.60	0.13	1.50	25	●
4.00	85	60G2 0400/0,75/0,16/7,2-085	+0/-0.005	h5	7.20	60.2	0.30	0.75	0.16	2.00	25	●
4.00	95	54G2 0400/0,90/0,20/9,0-095	+0/-0.005	h5	9.00	54.4	0.30	0.90	0.20	2.50	25	●
4.00	105	50G2 0400/1,05/0,25/10,6-105	+0/-0.005	h5	10.60	49.9	0.30	1.05	0.25			●
4.00	120	46G2 0400/1,25/0,30/12,0-120	+0/-0.005	h5	12.00	46.3	0.30	1.25	0.30			●
4.00	140	38G2 0400/1,50/0,35/16,2-140	+0/-0.004	h5	16.20	37.8	0.30	1.50	0.35			●
4.00	160	35G2 0400/1,70/0,40/18,0-160	+0/-0.004	h5	18.00	34.9	0.30	1.70	0.40			●
4.00	180	30G2 0400/2,00/0,45/21,8-180	+0/-0.004	h5	21.80	30.0	0.30	2.00	0.45			○

with power chamber

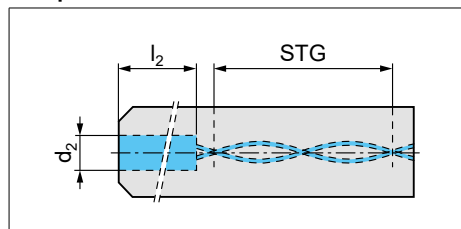

without power chamber

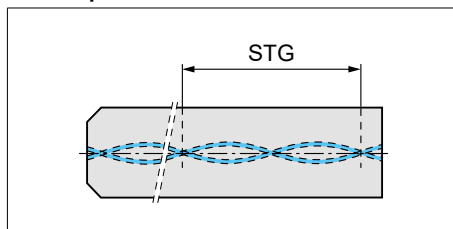

○ limited stock ● stock item ▲ new stock item Other grades and dimensions upon request

Rods with helical coolant holes

Our range of sintered and ground rods with helical coolant holes supports the production of drills in a diameter range from 3 mm to 35 mm.

Our rods with helical coolant holes are available in the proven CTS20D grade for the universal machining of steel, stainless steel or heat-resistant alloys, and now also in CTS12D and the new high-performance grade CTS24Z for the machining of difficult materials like titanium or Inconel. Having virtually the same hardness, CTS24Z is even tougher than our proven CTS18D and CTS20D grades. This extreme toughness offers maximum protection against breakage and ensures consistent performance of your tools.

Of course we can also produce carbide rods in other dimensions and grades to order – just get in touch with your contact person at CERATIZIT.

Detailed technical data for our rods with helical coolant holes can be found in the 'Information' section.



As sintered

With two coolant holes, $\leq 22^\circ$

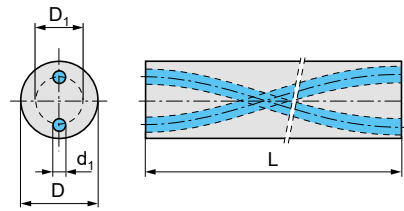

D [mm]	L [mm]	Type, description	Nominal pitch		D ₁ [mm]	d ₁ [mm]	CTS12D	CTS20D
			[mm]	[°]				
6.30	415	22R2 0630/1,9/0,6/46,9-415	46.90	21.9	1.90	0.60		●
6.30	330	15R2 0630/2,6/0,7/70,35-330	70.35	15.0	2.60	0.70	○	●
6.30	415	15R2 0630/2,6/0,7/70,35-415	70.35	15.0	2.60	0.70		●
8.30	415	20R2 0830/3,3/1,0/70,34-415	70.34	19.7	3.30	1.00		●
8.30	330	15R2 0830/3,6/1,25/93,8-330	93.80	15.0	3.60	1.25	○	●
8.30	415	15R2 0830/3,6/1,25/93,8-415	93.80	15.0	3.60	1.25		●
10.30	415	19R2 1030/4,40/1,20/93,80-415	93.80	18.5	4.40	1.20		●
10.30	330	15R2 1030/4,80/1,40/117,25-330	117.25	15.0	4.80	1.40	○	●
10.30	415	15R2 1030/4,80/1,40/117,25-415	117.25	15.0	4.80	1.40		●
12.30	415	18R2 1230/5,40/1,50/117,25-415	117.25	17.8	5.40	1.50		●
12.30	330	15R2 1230/6,25/1,55/140,70-330	140.70	15.0	6.25	1.55	○	●
12.30	415	15R2 1230/6,25/1,55/140,70-415	140.70	15.0	6.25	1.55		●
14.30	330	15R2 1430/6,70/1,90/164,14-330	164.14	15.0	6.70	1.90	○	●
14.30	415	15R2 1430/6,70/1,90/164,14-415	164.14	15.0	6.70	1.90		●
16.30	330	15R2 1630/8,0/2,10/187,59-330	187.59	15.0	8.00	2.10	○	●
18.30	330	15R2 1830/9,0/2,3/211,0-330	211.00	15.0	9.00	2.30	○	●
20.30	330	15R2 2030/10,0/2,50/234,49-330	234.49	15.0	10.00	2.50	○	●
22.30	330	15R2 2230/12,0/2,5/257,94-330	257.94	15.0	12.00	2.50		●

As sintered

With two coolant holes, 23° – 49°

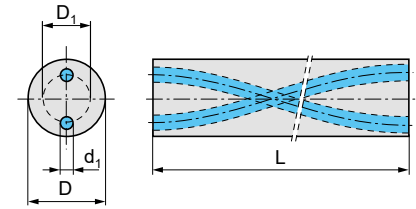

D [mm]	L [mm]	Type, description	Nominal pitch [mm]	[°]	D ₁ [mm]	d ₁ [mm]	CTS12D	CTS20D	CTS24Z
3.30	330	40R2 0330/0,3/0,15/11,2-330	11.20	40.1	0.30	0.15		●	
3.30	330	49R2 0330/0,55/0,20/8,2-330	8.20	49.0	0.55	0.20		●	
3.30	330	39R2 0330/0,8/0,23/11,5-330	11.50	39.3	0.80	0.23		●	
3.30	330	34R2 0330/1,1/0,35/14,0-330	14.00	34.0	1.10	0.35		●	
3.30	330	30R2 0330/1,4/0,35/16,32-330	16.32	30.0	1.40	0.35		●	
4.30	330	46R2 0430/1,0/0,3/12,0-330	12.00	46.3	1.00	0.30		●	
4.30	330	38R2 0430/1,2/0,35/16,2-330	16.20	37.8	1.20	0.35		●	
4.30	330	35R2 0430/1,6/0,45/18,0-330	18.00	34.9	1.60	0.45		●	
4.30	330	30R2 0430/2,1/0,45/21,8-330	21.80	30.0	2.10	0.45		●	
5.30	330	33R2 0530/2,2/0,6/24,5-330	24.50	32.7	2.20	0.60		●	
6.30	330	46R2 0630/1,6/0,5/18,0-330	18.00	46.3	1.60	0.50	●	●	●
6.30	330	40R2 0630/1,9/0,7/22,5-330	22.50	40.0	1.90	0.70	●	●	●
6.30	330	30R2 0630/2,0/0,9/32,7-330	32.70	30.0	2.00	0.90		●	
6.30	330	30R2 0630/2,2/0,7/32,7-330	32.70	30.0	2.20	0.70		●	
6.30	330	30R2 0630/2,7/0,8/32,7-330	32.70	30.0	2.70	0.80	○	●	●
6.30	330	30R2 0630/3,0/0,9/32,7-330	32.70	30.0	3.00	0.90		●	
6.30	350	46R2 0630/1,6/0,5/18,0-350	18.00	46.3	1.60	0.50		●	
6.30	350	40R2 0630/1,9/0,7/22,5-350	22.50	40.0	1.90	0.70		●	
6.30	350	30R2 0630/2,2/0,7/32,7-350	32.70	30.0	2.20	0.70		●	
6.80	330	30R2 0680/2,7/0,8/35,4-330	35.40	28.0	2.70	0.80	○		
6.80	330	30R2 0680/3,3/0,9/35,4-330	35.40	28.0	3.30	0.90		○	
7.30	330	30R2 0730/3,5/1,0/38,1-330	38.10	30.0	3.50	1.00		●	
8.30	330	43R2 0830/2,3/0,7/27,2-330	27.20	42.7	2.30	0.70		●	
8.30	330	40R2 0830/2,9/0,7/30,0-330	30.00	40.0	2.90	0.70	●	●	●
8.30	330	36R2 0830/3,3/1,0/35,0-330	35.00	35.7	3.30	1.00		●	
8.30	330	30R2 0830/3,4/1,0/43,5-330	43.50	30.0	3.40	1.00	●	●	●
8.30	330	30R2 0830/4,1/1,2/43,5-330	43.50	30.0	4.10	1.20		●	
8.30	350	36R2 0830/3,3/1,0/35,0-350	35.00	35.7	3.30	1.00		●	
8.30	350	30R2 0830/3,4/1,0/43,5-350	43.50	30.0	3.40	1.00		●	
9.30	330	30R2 0930/4,35/1,0/49,0-330	49.00	30.0	4.35	1.00		●	



○ limited stock ● stock item ▲ new stock item Other grades and dimensions upon request

As sintered

With two coolant holes, 23° – 49°

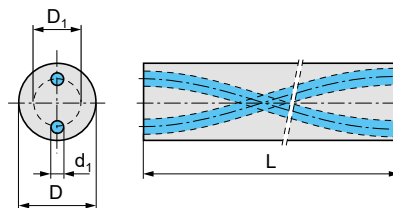

D [mm]	L [mm]	Type, description	Nominal pitch [mm]	[°]	D ₁ [mm]	d ₁ [mm]	CTS12D	CTS20D	CTS24Z
9.80	330	30R2 0980/4,8/1,3/51,7-330	51.70	28.7	4.80	1.30		○	
10.30	330	40R2 1030/2,7/0,8/37,0-330	37.00	40.3	2.70	0.80	●	●	●
10.30	330	34R2 1030/3,9/1,1/46,0-330	46.00	34.3	3.90	1.10		●	
10.30	330	34R2 1030/4,4/1,15/46,0-330	46.00	34.3	4.40	1.15		●	
10.30	330	30R2 1030/4,8/1,3/54,4-330	54.40	30.0	4.80	1.30	●	●	●
10.30	330	33R2 1030/5,0/1,2/49,0-330	49.00	32.7	5.00	1.20		●	
11.30	330	40R2 1130/3,2/0,8/41,2-330	41.20	40.0	3.20	0.80		●	
11.30	330	30R2 1130/5,5/1,5/59,9-330	59.90	30.0	5.50	1.50		●	
11.80	330	30R2 1180/5,5/1,5/62,6-330	62.60	28.9	5.50	1.50		○	
12.30	250	33R2 1230/5,4/1,5/57,0-250	57.00	33.5	5.40	1.50		●	
12.30	250	30R2 1230/6,3/1,7/65,3-250	65.30	30.0	6.30	1.70		●	
12.30	330	39R2 1230/3,5/1,0/46,3-330	46.30	39.2	3.50	1.00		●	
12.30	330	40R2 1230/4,0/0,9/44,9-330	44.90	40.0	4.00	0.90	●	●	●
12.30	330	33R2 1230/5,0/1,35/57,0-330	57.00	33.5	5.00	1.35		●	
12.30	330	33R2 1230/5,4/1,5/57,0-330	57.00	33.5	5.40	1.50		●	
12.30	330	32R2 1230/6,0/1,5/59,9-330	59.90	32.2	6.00	1.50		●	
12.30	330	30R2 1230/6,3/1,7/65,3-330	65.30	30.0	6.30	1.70	●	●	●
13.30	330	40R2 1330/4,4/1,0/48,7-330	48.70	40.0	4.40	1.00		●	
13.30	330	30R2 1330/6,5/1,6/70,7-330	70.70	30.0	6.50	1.60		●	
14.30	330	40R2 1430/4,6/1,3/52,4-330	52.40	40.0	4.60	1.30	●	●	●
14.30	330	34R2 1430/6,0/1,6/65,0-330	65.00	34.1	6.00	1.60		●	
14.30	330	30R2 1430/6,7/1,8/76,2-330	76.20	30.0	6.70	1.80	●	●	●
14.30	330	30R2 1430/7,0/2,0/76,2-330	76.20	30.0	7.00	2.00		●	
14.30	330	30R2 1430/7,6/2,0/76,2-330	76.20	30.0	7.60	2.00		●	
15.30	330	30R2 1530/7,6/2,0/81,6-330	81.60	30.0	7.60	2.00		●	
16.30	280	30R2 1630/8,0/2,0/87,1-280	87.10	30.0	8.00	2.00		●	
16.30	330	40R2 1630/5,5/1,2/59,9-330	59.90	40.0	5.50	1.20	●	●	●
16.30	330	35R2 1630/7,0/2,0/73,0-330	73.00	34.6	7.00	2.00		●	
16.30	330	30R2 1630/8,0/2,0/87,1-330	87.10	30.0	8.00	2.00	●	●	●
16.30	330	32R2 1630/8,4/2,0/81,6-330	81.60	31.6	8.40	2.00		●	



○ limited stock ● stock item ▲ new stock item Other grades and dimensions upon request

As sintered

With two coolant holes, 23° – 49°

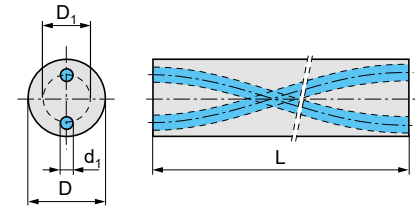

D [mm]	L [mm]	Type, description	Nominal pitch [mm]	[°]	D ₁ [mm]	d ₁ [mm]	CTS12D	CTS20D	CTS24Z
16.30	330	30R2 1630/8,6/2,5/87,1-330	87.10	30.0	8.60	2.50		●	
17.30	330	40R2 1730/5,75/1,3/63,6-330	63.60	40.0	5.75	1.30		●	
17.30	330	30R2 1730/8,9/2,5/92,5-330	92.50	30.0	8.90	2.50		●	
18.30	330	40R2 1830/5,6/1,6/68,0-330	68.00	39.7	5.60	1.60	●	●	●
18.30	330	40R2 1830/6,3/1,7/68,0-330	68.00	39.7	6.30	1.70		●	
18.30	330	35R2 1830/7,75/2,2/82,0-330	82.00	34.6	7.75	2.20		●	
18.30	330	30R2 1830/9,3/2,7/98,0-330	98.00	30.0	9.30	2.70	●	●	●
19.80	330	30R2 1980/9,6/2,4/106,1-330	106.10	29.4	9.60	2.40		○	
20.30	330	37R2 2030/6,5/1,7/84,3-330	84.30	36.7	6.50	1.70		●	
20.30	330	40R2 2030/7,1/1,5/74,9-330	74.90	40.0	7.10	1.50	●	●	●
20.30	330	30R2 2030/10,0/2,5/108,8-330	108.80	30.0	10.00	2.50	●	●	●
20.30	330	30R2 2030/10,7/3,2/108,8-330	108.80	30.0	10.70	3.20		●	
21.30	330	30R2 2130/10,65/2,0/114,2-330	114.20	30.0	10.65	2.00		●	
21.30	330	30R2 2130/11,5/3,2/114,2-330	114.20	30.0	11.50	3.20		○	
22.30	330	40R2 2230/7,7/1,7/82,4-330	82.40	40.0	7.70	1.70		●	
22.30	330	33R2 2230/10,0/2,50/108,0-330	108.00	32.6	10.00	2.50		●	
22.30	330	30R2 2230/11,3/2,0/119,7-330	119.70	30.0	11.30	2.00		●	
22.30	330	30R2 2230/11,5/3,4/119,7-330	119.70	30.0	11.50	3.40		○	
25.30	330	40R2 2530/7,7/1,75/93,6-330	93.60	40.0	7.70	1.75		●	●
25.30	330	33R2 2530/12,0/3,2/119,0-330	119.00	33.0	12.00	3.20		●	●
28.30	330	39R2 2830/9,0/2,0/107,7-330	107.70	39.2	9.00	2.00		●	
28.30	330	29R2 2830/14,8/2,5/159,0-330	159.00	29.0	14.80	2.50		●	
30.30	330	39R2 3030/10,0/2,0/116,0-330	116.00	39.1	10.00	2.00		●	
30.30	330	29R2 3030/16,0/2,5/172,0-330	172.00	28.7	16.00	2.50		●	
32.30	330	40R2 3230/11,0/2,0/119,8-330	119.80	40.0	11.00	2.00		●	
32.30	330	29R2 3230/17,0/3,0/177,8-330	177.80	29.5	17.00	3.00		●	
35.30	330	30R2 3530/18,0/3,0/189,5-330	189.50	30.0	18.00	3.00		●	

○ limited stock ● stock item ▲ new stock item Other grades and dimensions upon request

As sintered

With two coolant holes, extra-long, 23° – 49°

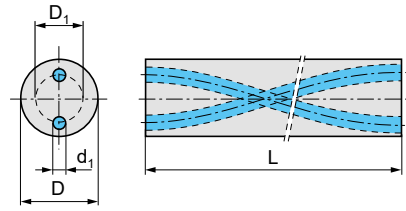

D [mm]	L [mm]	Type, description	Nominal pitch		D ₁ [mm]	d ₁ [mm]	CTS20D
			[mm]	[°]			
6.30	430	46R2 0630/1,6/0,5/18,0-430	18.00	46.3	1.60	0.50	●
6.30	430	40R2 0630/1,9/0,7/22,5-430	22.50	40.0	1.90	0.70	●
6.30	430	30R2 0630/2,2/0,7/32,7-430	32.70	30.0	2.20	0.70	●
6.30	430	30R2 0630/3,0/0,9/32,7-430	32.70	30.0	3.00	0.90	●
8.30	430	30R2 0830/3,4/1,0/43,5-430	43.50	30.0	3.40	1.00	●
10.30	430	30R2 1030/4,8/1,3/54,4-430	54.40	30.0	4.80	1.30	●
10.30	530	30R2 1030/4,8/1,3/54,4-530	54.40	30.0	4.80	1.30	●
12.30	430	30R2 1230/6,3/1,7/65,3-430	65.30	30.0	6.30	1.70	●
12.30	530	30R2 1230/6,3/1,7/65,3-530	65.30	30.0	6.30	1.70	●
14.30	430	30R2 1430/6,7/1,8/76,2-430	76.20	30.0	6.70	1.80	●
14.30	530	30R2 1430/6,7/1,8/76,2-530	76.20	30.0	6.70	1.80	●
16.30	430	30R2 1630/8,0/2,0/87,1-430	87.10	30.0	8.00	2.00	●
16.30	530	30R2 1630/8,0/2,0/87,1-530	87.10	30.0	8.00	2.00	●
18.30	530	30R2 1830/9,3/2,7/98,0-530	98.00	30.0	9.30	2.70	●
18.30	430	30R2 1830/9,3/2,7/98,0-430	98.00	30.0	9.30	2.70	●
20.30	430	30R2 2030/10,0/2,5/108,8-430	108.80	30.0	10.00	2.50	●
20.30	530	30R2 2030/10,0/2,5/108,8-530	108.80	30.0	10.00	2.50	●
25.30	530	33R2 2530/12,0/3,2/119,0-530	119.00	33.4	12.00	3.20	●
25.30	430	33R2 2530/12,0/3,2/119,0-430	119.00	33.4	12.00	3.20	●

As sintered

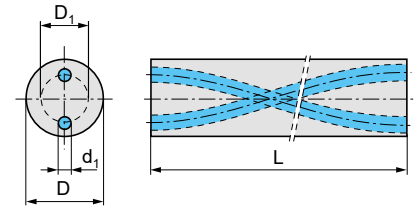
With two coolant holes, $\geq 50^\circ$ 

D [mm]	L [mm]	Type, description	Nominal pitch		D ₁ [mm]	d ₁ [mm]	CTS20D
			[mm]	[°]			
10.30	330	50R2 1030/2,3/0,7/26,0-330	26.00	50.4	2.30	0.70	●
12.30	330	51R2 1230/2,3/0,7/30,1-330	30.10	51.4	2.30	0.70	●
13.30	330	50R2 1330/2,6/0,7/34,0-330	34.00	50.2	2.60	0.70	●
16.30	330	50R2 1630/3,7/1,0/42,0-330	42.00	50.1	3.70	1.00	●
20.30	330	50R2 2030/4,4/1,2/52,7-330	52.70	50.0	4.40	1.20	●

○ limited stock ● stock item ▲ new stock item Other grades and dimensions upon request

As sintered

With three coolant holes

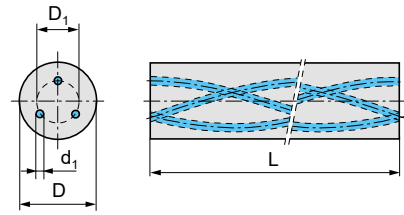

D [mm]	L [mm]	Type, description	Nominal pitch		D ₁ [mm]	d ₁ [mm]	CTS20D
			[mm]	[°]			
6.30	330	30R3 0630/3,0/0,6/32,7-330	32.70	31.2	3.00	0.60	●
8.30	330	40R3 0830/2,9/0,7/30,0-330	30.00	40.0	2.90	0.70	●
8.30	330	30R3 0830/4,0/0,75/43,5-330	43.50	30.0	4.00	0.75	●
10.30	330	40R3 1030/3,5/0,75/37,0-330	37.00	40.3	3.50	0.75	●
10.30	330	30R3 1030/4,9/1,0/54,4-330	54.40	30.0	4.90	1.00	●
12.30	330	40R3 1230/4,0/0,9/44,9-330	44.90	40.0	4.00	0.90	●
12.30	330	30R3 1230/6,0/1,1/65,3-330	65.30	30.0	6.00	1.10	●
14.30	330	40R3 1430/4,65/1,2/52,4-330	52.40	40.0	4.65	1.20	●
14.30	330	30R3 1430/7,1/1,3/76,2-330	76.20	30.0	7.10	1.30	●
16.30	330	40R3 1630/5,5/1,2/59,9-330	59.90	40.0	5.50	1.20	●
16.30	330	30R3 1630/8,3/1,5/87,0-330	87.00	30.0	8.30	1.50	●
18.30	330	40R3 1830/6,25/1,5/67,4-330	67.40	40.0	6.25	1.50	●
18.30	330	30R3 1830/9,6/1,7/98,0-330	98.00	30.0	9.60	1.70	●
20.30	330	40R3 2030/7,1/1,5/74,9-330	74.90	40.0	7.10	1.50	●
20.30	330	30R3 2030/10,4/2,0/108,8-330	108.80	30.0	10.40	2.00	●
22.30	330	40R3 2230/7,7/1,7/82,4-330	82.40	40.0	7.70	1.70	●
22.30	330	30R3 2230/10,7/2,0/119,7-330	119.70	30.0	10.70	2.00	●
25.30	330	40R3 2530/8,1/1,7/93,6-330	93.60	40.0	8.10	1.70	●
25.30	330	33R3 2530/11,5/2,2/119,0-330	119.00	33.4	11.50	2.20	●

○ limited stock ● stock item ▲ new stock item Other grades and dimensions upon request

As sintered

With four coolant holes

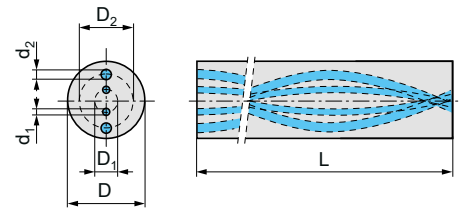

D [mm]	L [mm]	Type, description	Nominal pitch		D ₁ [mm]	d ₁ [mm]	D ₂ [mm]	d ₂ [mm]	CTS20D
			[mm]	[°]					
8.30	330	33R4 0830/1,9/3,9/0,4/0,8/38-330	38.10	33.4	1.90	0.40	3.90	0.80	●
8.30	330	30R4 0830/2,2/4,5/0,45/0,9/44-330	43.50	29.7	2.20	0.45	4.50	0.90	○
10.30	330	33R4 1030/2,5/5,1/0,5/1,0/49-330	49.00	32.7	2.50	0.50	5.10	1.00	●
10.30	330	30R4 1030/2,8/5,7/0,6/1,1/54-330	54.40	30.0	2.80	0.60	5.70	1.10	●
12.30	330	32R4 1230/3,1/6,3/0,7/1,2/60-330	59.90	32.2	3.10	0.70	6.30	1.20	●
12.30	330	30R4 1230/3,4/6,9/0,7/1,4/65-330	65.30	30.0	3.40	0.70	6.90	1.40	●
14.30	330	32R4 1430/3,6/7,5/0,8/1,5/70-330	70.70	31.9	3.60	0.80	7.50	1.50	●
14.30	330	30R4 1430/3,9/8,1/0,8/1,6/76-330	76.20	30.0	3.90	0.80	8.10	1.60	●
16.30	330	30R4 1630/4,4/9,0/0,9/1,8/87-330	87.10	30.0	4.40	0.90	9.00	1.80	●
18.30	330	30R4 1830/5,0/10,2/1,0/2,0/98-330	98.00	30.0	5.00	1.00	10.20	2.00	●
20.30	330	30R4 203/5,6/11,4/1,2/2,3/109-330	108.80	30.0	5.60	1.20	11.40	2.30	●
22.30	330	30R4 223/6,1/12,6/1,2/2,5/120-330	119.70	30.0	6.10	1.20	12.60	2.50	○
25.30	330	29R4 253/6,9/14,1/1,4/2,8/139-330	139.30	29.4	6.90	1.40	14.10	2.80	●

○ limited stock ● stock item ▲ new stock item Other grades and dimensions upon request

Ground

With two coolant holes, $\leq 22^\circ$

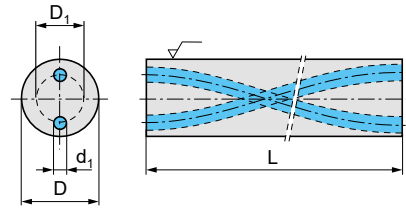

D [mm]	L [mm]	Type, description	Dia. tol.		Nominal pitch		D ₁ [mm]	d ₁ [mm]	CTS20D
			[mm]	ISO 286	[mm]	[°]			
6.00	330	15G2 0600/2,6/0,7/70,35-330	+0/-0.008	h6	70.35	15.0	2.60	0.70	●
8.00	330	15G2 0800/3,6/1,25/93,8-330	+0/-0.009	h6	93.80	15.0	3.60	1.25	●
10.00	330	15G2 1000/4,80/1,40/117,25-330	+0/-0.009	h6	117.25	15.0	4.80	1.40	●
12.00	330	15G2 1200/6,25/1,55/140,70-330	+0/-0.011	h6	140.70	15.0	6.25	1.55	●
14.00	330	15G2 1400/6,70/1,90/164,14-330	+0/-0.011	h6	164.14	15.0	6.70	1.90	●
16.00	330	15G2 1600/8,0/2,10/187,59-330	+0/-0.011	h6	187.59	15.0	8.00	2.10	●
18.00	330	15G2 1800/9,0/2,3/211,0-330	+0/-0.011	h6	211.00	15.0	9.00	2.30	●
20.00	330	15G2 2000/10,0/2,50/234,49-330	+0/-0.013	h6	234.49	15.0	10.00	2.50	●

Ground

With two coolant holes, 23° – 49°

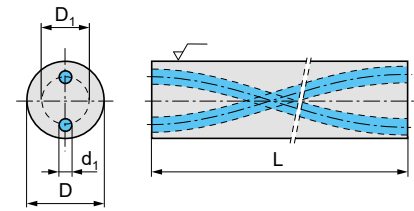

D [mm]	L [mm]	Type, description	Dia. tol.		Nominal pitch		D ₁ [mm]	d ₁ [mm]	CTS20D
			[mm]	ISO 286	[mm]	[°]			
6.00	330	40G2 0600/1,9/0,7/22,5-330	+0/-0.008	h6	22.50	40.0	1.90	0.70	●
6.00	330	30G2 0600/3,0/0,9/32,7-330	+0/-0.008	h6	32.70	30.0	3.00	0.90	●
8.00	330	43G2 0800/2,3/0,7/27,2-330	+0/-0.009	h6	27.20	42.7	2.30	0.70	●
8.00	330	30G2 0800/3,4/1,0/43,5-330	+0/-0.009	h6	43.50	30.0	3.40	1.00	●
10.00	330	40G2 1000/2,7/0,8/37,0-330	+0/-0.009	h6	37.00	40.0	2.70	0.80	●
10.00	330	30G2 1000/4,8/1,3/54,4-330	+0/-0.009	h6	54.40	30.0	4.80	1.30	●
12.00	330	39G2 1200/3,5/1,0/46,3-330	+0/-0.011	h6	46.30	39.0	3.50	1.00	●
12.00	330	30G2 1200/6,3/1,7/65,3-330	+0/-0.011	h6	65.30	30.0	6.30	1.70	●
14.00	330	40G2 1400/4,6/1,3/52,4-330	+0/-0.011	h6	52.40	40.0	4.60	1.30	●
14.00	330	30G2 1400/6,7/1,8/76,2-330	+0/-0.011	h6	76.20	30.0	6.70	1.80	●
16.00	330	40G2 1600/5,5/1,2/59,9-330	+0/-0.011	h6	59.90	40.0	5.50	1.20	●
16.00	330	30G2 1600/8,0/2,0/87,1-330	+0/-0.011	h6	87.10	30.0	8.00	2.00	●
18.00	330	40G2 1800/6,3/1,7/68,0-330	+0/-0.011	h6	68.00	39.7	6.30	1.70	●
18.00	330	30G2 1800/9,3/2,7/98,0-330	+0/-0.011	h6	98.00	30.0	9.30	2.70	●
20.00	330	40G2 2000/7,1/1,5/74,9-330	+0/-0.013	h6	74.90	40.0	7.10	1.50	●
20.00	330	30G2 2000/10,0/2,5/108,8-330	+0/-0.013	h6	108.80	30.0	10.00	2.50	●
25.00	330	40G2 2500/7,7/1,75/93,6-330	+0/-0.013	h6	93.60	40.0	7.70	1.75	●
25.00	330	33G2 2500/12,0/3,2/119,0-330	+0/-0.013	h6	119.00	33.4	12.0	3.20	●
32.00	330	40G2 3200/11,0/2,0/119,8-330	+0/-0.016	h6	119.80	40.0	11.00	2.00	●
32.00	330	29G2 3200/17,0/3,0/177,8-330	+0/-0.016	h6	177.80	29.5	17.00	3.00	●

○ limited stock ● stock item ▲ new stock item Other grades and dimensions upon request

Ground

With three coolant holes

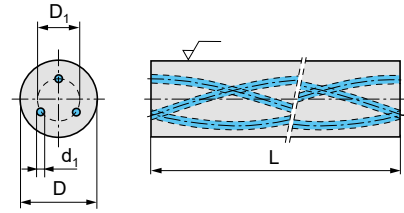

D [mm]	L [mm]	Type, description	Dia. tol.		Nominal pitch		D ₁ [mm]	d ₁ [mm]	CTS20D
			[mm]	ISO 286	[mm]	[°]			
6.00	330	30G3 0600/3,0/0,6/32,7-330	+0/-0.008	h6	32.70	30.0	3.00	0.60	●
8.00	330	30G3 0800/4,0/0,75/43,5-330	+0/-0.009	h6	43.50	30.0	4.00	0.75	●
10.00	330	30G3 1000/4,9/1,0/54,4-330	+0/-0.009	h6	54.40	30.0	4.90	1.00	●
12.00	330	30G3 1200/6,0/1,1/65,3-330	+0/-0.011	h6	65.30	30.0	6.00	1.10	●
14.00	330	30G3 1400/7,1/1,3/76,2-330	+0/-0.011	h6	76.20	30.0	7.10	1.30	●
16.00	330	30G3 1600/8,3/1,5/87,0-330	+0/-0.011	h6	87.00	30.0	8.30	1.50	●
18.00	330	30G3 1800/9,6/1,7/98,0-330	+0/-0.011	h6	98.00	30.0	9.60	1.70	●
20.00	330	30G3 2000/10,4/2,0/108,8-330	+0/-0.013	h6	108.80	30.0	10.40	2.00	●
25.00	330	33G3 2500/11,5/2,2/119,0-330	+0/-0.013	h6	119.00	33.0	11.50	2.20	●

○ limited stock ● stock item ▲ new stock item Other grades and dimensions upon request

Rods with straight coolant holes

Our standard range includes sintered and ground rods with one central or two straight coolant holes. In addition to our established carbide grades, we offer a selection of dimensions in the cermet grade CTF28T, which has been specially developed for the finish machining of steel.

Of course we can also produce carbide rods in other dimensions and grades to order – just get in touch with your contact person at CERATIZIT.

Detailed technical data for our rods with straight coolant holes can be found in the 'Information' section.



As sintered

With central coolant hole, ultra-fine grades

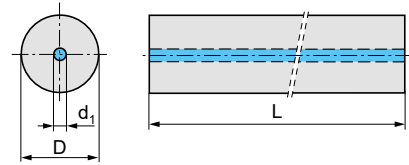

D [mm]	L [mm]	Type, description	d ₁ [mm]	TSF44
6.45	330	00R1 0645/1,0-330	1.00	●
8.55	330	00R1 0855/1,3-330	1.30	●
10.55	330	00R1 1055/1,3-330	1.30	●
10.55	330	00R1 1055/2,0-330	2.00	●
12.55	330	00R1 1255/2,0-330	2.00	●
14.70	330	00R1 1470/2,0-330	2.00	●
16.70	330	00R1 1670/2,0-330	2.00	●
20.70	330	00R1 2070/3,0-330	3.00	●

As sintered

With central coolant hole, submicron grades

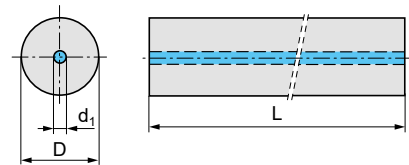

D [mm]	L [mm]	Type, description	d ₁ [mm]	CTS15D	CTS20D
4.95	330	00R1 0495/0,6-330	0.60	●	
6.30	330	00R1 0630/1,0-330	1.00		●
6.45	330	00R1 0645/1,0-330	1.00	●	
8.30	330	00R1 0830/1,3-330	1.30		●
8.55	330	00R1 0855/1,3-330	1.30	●	
8.55	330	00R1 0855/2,0-330	2.00	●	
10.30	330	00R1 1030/2,0-330	2.00		●
10.55	330	00R1 1055/1,3-330	1.30	●	
10.55	330	00R1 1055/2,0-330	2.00	●	
11.30	330	00R1 1130/2,0-330	2.00		●
12.30	330	00R1 1230/2,0-330	2.00		●
12.55	330	00R1 1255/2,0-330	2.00	●	



○ limited stock ● stock item ▲ new stock item Other grades and dimensions upon request

As sintered

With central coolant hole, submicron grades

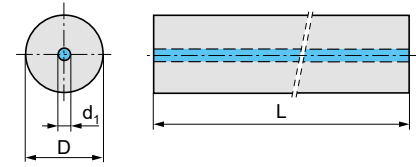

D [mm]	L [mm]	Type, description	d ₁ [mm]	CTS15D	CTS20D
13.30	330	00R1 1330/2,0-330	2.00		●
14.30	330	00R1 1430/2,0-330	2.00		●
14.70	330	00R1 1470/2,0-330	2.00	●	
16.30	330	00R1 1630/2,0-330	2.00		●
16.70	330	00R1 1670/2,0-330	2.00	●	
18.30	330	00R1 1830/3,0-330	3.00		●
18.70	330	00R1 1870/3,0-330	3.00	●	
20.30	330	00R1 2030/3,0-330	3.00		●
20.70	330	00R1 2070/3,0-330	3.00	●	
25.30	330	00R1 2530/3,0-330	3.00		●
28.30	330	00R1 2830/4,0-330	4.00		●
30.30	330	00R1 3030/5,0-330	5.00		●
32.30	330	00R1 3230/5,0-330	5.00		●

As sintered

With central coolant hole, cermet

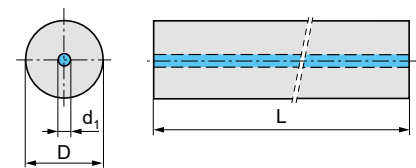

D [mm]	L [mm]	Type, description	d ₁ [mm]	CTF28T
6.45	330	00R1 0645/1,0-330	1.00	●
8.55	330	00R1 0855/1,3-330	1.30	●
10.55	330	00R1 1055/2,0-330	2.00	●
12.55	330	00R1 1255/2,0-330	2.00	●

○ limited stock ● stock item ▲ new stock item Other grades and dimensions upon request

As sintered

With two straight coolant holes, submicron grades

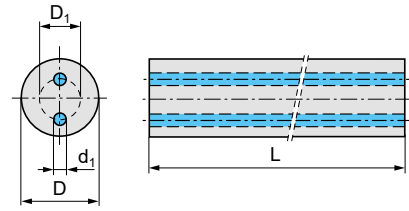

D [mm]	L [mm]	Type, description	D ₁ [mm]	d ₁ [mm]	CTS15D	CTS20D
3.30	330	00R2 0330/1,1/0,425-330	1.10	0.43	●	
4.20	330	00R2 0420/1,1/0,45-330	1.10	0.45	●	
5.20	330	00R2 0520/2,0/0,9-330	2.00	0.90	○	○
6.20	330	00R2 0620/1,1/0,5-330	1.10	0.50	●	
6.20	330	00R2 0620/1,5/0,9-330	1.50	0.90	●	
6.20	330	00R2 0620/1,7/0,6-330	1.70	0.60	●	●
6.20	330	00R2 0620/2,0/0,9-330	2.00	0.90	●	●
6.20	330	00R2 0620/2,3/0,9-330	2.30	0.90	●	
6.20	330	00R2 0620/2,6/0,9-330	2.60	0.90		●
6.20	330	00R2 0620/3,0/1,2-330	3.00	1.20	●	
7.20	330	00R2 0720/2,0/0,9-330	2.00	0.90	○	○
7.20	330	00R2 0720/3,0/0,9-330	3.00	0.90		●
8.20	330	00R2 0820/2,0/0,9-330	2.00	0.90	●	●
8.20	330	00R2 0820/2,6/0,9-330	2.60	0.90	●	
8.20	330	00R2 0820/2,6/1,2-330	2.60	1.20		●
8.20	330	00R2 0820/3,4/1,0-330	3.40	1.00		●
8.20	330	00R2 0820/3,5/1,5-330	3.50	1.50	●	
8.20	330	00R2 0820/4,0/0,9-330	4.00	0.90	●	●
9.20	330	00R2 0920/2,6/1,2-330	2.60	1.20		●
9.20	330	00R2 0920/3,5/1,5-330	3.50	1.50	●	
9.20	330	00R2 0920/3,8/1,2-330	3.80	1.20		●
9.20	330	00R2 0920/4,0/1,3-330	4.00	1.30	●	
10.20	330	00R2 1020/2,0/1,0-330	2.00	1.00	●	
10.20	330	00R2 1020/2,6/1,2-330	2.60	1.20		●
10.20	330	00R2 1020/2,8/1,0-330	2.80	1.00	●	
10.20	330	00R2 1020/3,5/1,5-330	3.50	1.50	●	
10.20	330	00R2 1020/4,2/1,4-330	4.20	1.40	●	●
10.20	330	00R2 1020/5,0/1,2-330	5.00	1.20	●	
10.20	330	00R2 1020/5,2/1,4-330	5.20	1.40	●	
12.20	330	00R2 1220/2,6/1,2-330	2.60	1.20	●	



○ limited stock ● stock item ▲ new stock item Other grades and dimensions upon request

As sintered

With two straight coolant holes, submicron grades

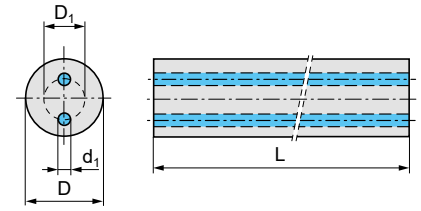

D [mm]	L [mm]	Type, description	D ₁ [mm]	d ₁ [mm]	CTS15D	CTS20D
12.20	330	00R2 1220/3,5/1,5-330	3.50	1.50	●	●
12.20	330	00R2 1220/4,8/1,5-330	4.80	1.50	●	
12.20	330	00R2 1220/5,0/2,0-330	5.00	2.00	●	●
12.20	330	00R2 1220/6,0/1,5-330	6.00	1.50	●	
13.20	330	00R2 1320/5,4/2,0-330	5.40	2.00		○
14.20	330	00R2 1420/3,5/1,5-330	3.50	1.50		●
14.20	330	00R2 1420/5,0/2,0-330	5.00	2.00	●	●
14.20	330	00R2 1420/5,0/1,7-330	5.00	1.70	●	
14.20	330	00R2 1420/5,8/2,0-330	5.80	2.00		●
14.20	330	00R2 1420/7,0/2,0-330	7.00	2.00	●	
15.20	330	00R2 1520/5,0/2,0-330	5.00	2.00	●	
16.20	330	00R2 1620/3,5/1,5-330	3.50	1.50	●	
16.20	330	00R2 1620/5,0/1,5-330	5.00	1.50	●	
16.20	330	00R2 1620/5,0/2,0-330	5.00	2.00	●	●
16.20	400	00R2 1620/6,2/2,0-400	6.20	2.00	●	
16.20	330	00R2 1620/6,6/2,5-330	6.60	2.50		●
16.20	330	00R2 1620/8,0/2,0-330	8.00	2.00	●	
16.20	415	00R2 1620/8,0/2,0-415	8.00	2.00	●	
18.20	330	00R2 1820/5,0/2,0-330	5.00	2.00	●	
18.20	330	00R2 1820/6,0/2,0-330	6.00	2.00	●	●
18.20	330	00R2 1820/7,5/2,5-330	7.50	2.50		●
18.20	330	00R2 1820/9,0/2,0-330	9.00	2.00	●	●
19.20	330	00R2 1920/7,9/2,5-330	7.90	2.50		○
20.20	330	00R2 2020/3,5/1,5-330	3.50	1.50	●	
20.20	330	00R2 2020/6,0/2,0-330	6.00	2.00		●
20.20	330	00R2 2020/6,2/2,0-330	6.20	2.00	●	
20.20	330	00R2 2020/8,2/2,5-330	8.20	2.50	●	
20.20	330	00R2 2020/10,0/2,5-330	10.00	2.50	●	
21.20	330	00R2 2120/7,0/2,3-330	7.00	2.30		●
22.20	330	00R2 2220/7,0/2,3-330	7.00	2.30		●



○ limited stock ● stock item ▲ new stock item Other grades and dimensions upon request

As sintered

With two straight coolant holes, submicron grades

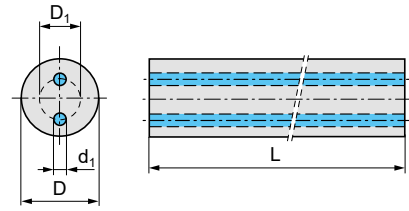

D [mm]	L [mm]	Type, description	D ₁ [mm]	d ₁ [mm]	CTS15D	CTS20D
22.20	330	00R2 2220/10,5/3,0-330	10.50	3.00		●
25.30	330	00R2 2530/6,2/2,0-330	6.20	2.00	●	●
25.30	330	00R2 2530/8,0/2,0-330	8.00	2.00	●	
25.30	330	00R2 2530/10,0/2,5-330	10.00	2.50	●	
25.30	330	00R2 2530/12,0/3,0-330	12.00	3.00	●	●
26.30	330	00R2 2630/7,5/2,0-330	7.50	2.00		●
26.30	330	00R2 2630/12,0/3,0-330	12.00	3.00		●
28.30	330	00R2 2830/13,0/3,0-330	13.00	3.00		●
30.30	330	00R2 3030/13,0/3,0-330	13.00	3.00		●
32.30	330	00R2 3230/9,0/2,2-330	9.00	2.20		●
32.30	330	00R2 3230/13,8/3,0-330	13.80	3.00		●
34.30	330	00R2 3430/13,8/3,0-330	13.80	3.00		●

○ limited stock ● stock item ▲ new stock item Other grades and dimensions upon request

Ground

With central coolant hole, submicron grades

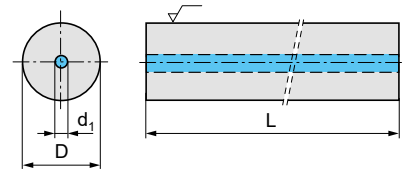

D [mm]	L [mm]	Type, description	Dia. tol.		d ₁ [mm]	CTS15D
			[mm]	ISO 286		
6.00	330	00G1 0600/1,0-330	+0/-0.008	h6	1.00	●
8.00	330	00G1 0800/1,3-330	+0/-0.009	h6	1.30	●
10.00	330	00G1 1000/2,0-330	+0/-0.009	h6	2.00	●
12.00	330	00G1 1200/2,0-330	+0/-0.011	h6	2.00	●
14.00	330	00G1 1400/2,0-330	+0/-0.011	h6	2.00	●
16.00	330	00G1 1600/2,0-330	+0/-0.011	h6	2.00	●
16.00	330	00G1 1600/3,0-330	+0/-0.011	h6	3.00	●
20.00	330	00G1 2000/3,0-330	+0/-0.013	h6	3.00	●
25.00	330	00G1 2500/3,0-330	+0/-0.013	h6	3.00	●
32.00	330	00G1 3200/5,0-330	+0/-0.016	h6	5.00	●

○ limited stock ● stock item ▲ new stock item Other grades and dimensions upon request

Ground

With two coolant holes, submicron grades

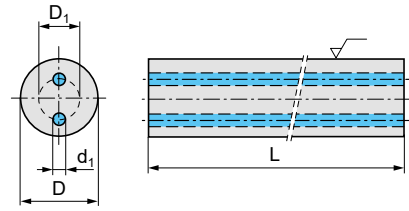

D [mm]	L [mm]	Type, description	Dia. tol. [mm]	ISO 286	D ₁ [mm]	d ₁ [mm]	CTS15D
6.00	330	00G2 0600/1,5/0,9-330	+0/-0.008	h6	1.50	0.90	●
6.00	330	00G2 0600/3,0/1,2-330	+0/-0.008	h6	3.00	1.20	●
8.00	330	00G2 0800/2,0/0,9-330	+0/-0.009	h6	2.00	0.90	●
8.00	330	00G2 0800/4,0/0,9-330	+0/-0.009	h6	4.00	0.90	●
10.00	330	00G2 1000/2,8/1,0-330	+0/-0.009	h6	2.80	1.00	●
10.00	330	00G2 1000/5,2/1,4-330	+0/-0.009	h6	5.20	1.40	●
12.00	330	00G2 1200/3,5/1,5-330	+0/-0.011	h6	3.50	1.50	●
12.00	330	00G2 1200/6,0/1,5-330	+0/-0.011	h6	6.00	1.50	●
14.00	330	00G2 1400/5,0/1,7-330	+0/-0.011	h6	5.00	1.70	●
14.00	330	00G2 1400/7,0/2,0-330	+0/-0.011	h6	7.00	2.00	●
16.00	330	00G2 1600/5,0/1,5-330	+0/-0.011	h6	5.00	1.50	●
16.00	330	00G2 1600/8,0/2,0-330	+0/-0.011	h6	8.00	2.00	●
18.00	330	00G2 1800/6,0/2,0-330	+0/-0.011	h6	6.00	2.00	●
18.00	330	00G2 1800/9,0/2,0-330	+0/-0.011	h6	9.00	2.00	●
20.00	330	00G2 2000/6,2/2,0-330	+0/-0.013	h6	6.20	2.00	●
20.00	330	00G2 2000/10,0/2,5-330	+0/-0.013	h6	10.00	2.50	●
25.00	330	00G2 2500/6,2/2,0-330	+0/-0.013	h6	6.20	2.00	●
25.00	330	00G2 2500/8,0/2,0-330	+0/-0.013	h6	8.00	2.00	●
25.00	330	00G2 2500/12,0/3,0-330	+0/-0.013	h6	12.00	3.00	●

○ limited stock ● stock item ▲ new stock item Other grades and dimensions upon request

Blanks for gun drills

We offer a complete stock range of rods and tips for the production of solid carbide or brazed gun drills. These include rods with a kidney-shaped coolant hole, profiled rods with one or two coolant holes and profiled tips with two coolant holes.

Our blanks for gun drills are available in the proven CTS20D grade for the universal machining of steel, stainless steel or heat-resistant alloys: some dimensions can also be ordered in grade CTF12E, a fine-grain grade specifically for gun drills with an optimised balance between hardness and toughness.

Of course we can also produce carbide rods in other dimensions and grades to order – just get in touch with your contact person at CERATIZIT.

Detailed technical data for our gun drill blanks can be found in the 'Information' section.



Rods

Rods with kidney-shaped coolant holes, submicron grades

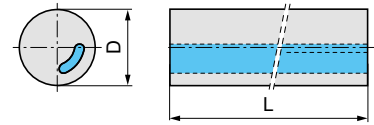

Technical drawings upon request

D [mm]	L [mm]	Type, description	Dia. tol. [mm]	CTS20D
2.40	310	GDRK 0240-310	±0.15	●
2.60	310	GDRK 0260-310	±0.15	●
2.90	310	GDRK 0290-310	±0.15	●
3.15	310	GDRK 0315-310	±0.15	○
3.45	310	GDRK 0345-310	±0.15	●
3.50	310	GDRK 0350-310	±0.15	●
3.90	310	GDRK 0390-310	±0.15	●
4.40	310	GDRK 0440-310	±0.15	●
4.90	310	GDRK 0490-310	±0.15	●
5.50	310	GDRK 0550-310	±0.15	●
6.00	310	GDRK 0600-310	±0.15	●
6.50	310	GDRK 0650-310	±0.15	●
7.10	310	GDRK 0710-310	±0.15	○
7.60	310	GDRK 0760-310	±0.15	○
8.10	310	GDRK 0810-310	±0.15	○
8.30	310	GDRK 0830-310	±0.15	●
8.70	310	GDRK 0870-310	±0.15	○
9.20	310	GDRK 0920-310	±0.15	○
10.60	310	GDRK 1060-310	±0.15	○
11.30	310	GDRK 1130-310	±0.15	○

○ limited stock ● stock item ▲ new stock item Other grades and dimensions upon request

Rods

Rods with kidney-shaped coolant hole, fine grain grades

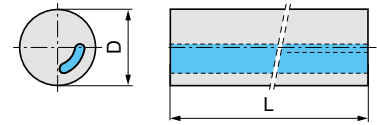

Technical drawings upon request

D [mm]	L [mm]	Type, description	Dia. tol. [mm]	CTF12E
2.40	310	GDRK 0240-310	±0.15	●
2.60	310	GDRK 0260-310	±0.15	○
2.90	310	GDRK 0290-310	±0.15	●
3.15	310	GDRK 0315-310	±0.15	○
3.45	310	GDRK 0345-310	±0.15	○
3.50	310	GDRK 0350-310	±0.15	○
3.90	310	GDRK 0390-310	±0.15	○
4.40	310	GDRK 0440-310	±0.15	●
4.90	310	GDRK 0490-310	±0.15	○
5.50	310	GDRK 0550-310	±0.15	●
6.00	310	GDRK 0600-310	±0.15	○
6.50	310	GDRK 0650-310	±0.15	●
7.10	310	GDRK 0710-310	±0.15	○
7.60	310	GDRK 0760-310	±0.15	○
8.10	310	GDRK 0810-310	±0.15	○
8.30	310	GDRK 0830-310	±0.15	○
8.70	310	GDRK 0870-310	±0.15	○
9.20	310	GDRK 0920-310	±0.15	○
10.60	310	GDRK 1060-310	±0.15	○
11.30	310	GDRK 1130-310	±0.15	○

○ limited stock ● stock item ▲ new stock item Other grades and dimensions upon request

Rods

Profiled rods with kidney-shaped coolant hole, 120°, submicron grades

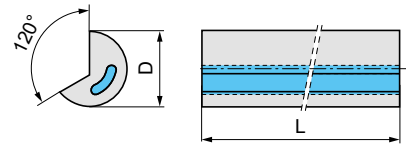

Technical drawings upon request

D [mm]	L [mm]	Type, description	Dia. tol. [mm]	CTS20D
2.40	310	GDVK 0240-310	±0.15	○
2.60	310	GDVK 0260-310	±0.15	○
2.90	310	GDVK 0290-310	±0.15	○
3.15	310	GDVK 0315-310	±0.15	○
3.45	310	GDVK 0345-310	±0.15	●
3.90	310	GDVK 0390-310	±0.15	●
4.40	310	GDVK 0440-310	±0.15	●
4.90	310	GDVK 0490-310	±0.15	●
5.50	310	GDVK 0550-310	±0.15	●
6.00	310	GDVK 0600-310	±0.15	●
6.50	310	GDVK 0650-310	±0.15	●
7.10	310	GDVK 0710-310	±0.15	●
7.60	310	GDVK 0760-310	±0.15	○
8.10	310	GDVK 0810-310	±0.15	○
8.70	310	GDVK 0870-310	±0.15	●
9.20	310	GDVK 0920-310	±0.15	○

○ limited stock ● stock item ▲ new stock item Other grades and dimensions upon request

Rods

Profiled rods with kidney-shaped coolant hole, 120°, fine grain grades

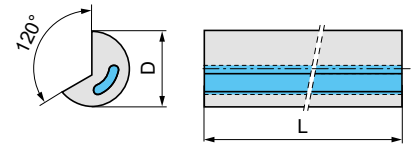

Technical drawings upon request

D [mm]	L [mm]	Type, description	Dia. tol. [mm]	CTF12E
2.40	310	GDVK 0240-310	±0.15	●
2.60	310	GDVK 0260-310	±0.15	●
2.90	310	GDVK 0290-310	±0.15	●
3.15	310	GDVK 0315-310	±0.15	●
3.45	310	GDVK 0345-310	±0.15	●
3.90	310	GDVK 0390-310	±0.15	●
4.40	310	GDVK 0440-310	±0.15	●
4.90	310	GDVK 0490-310	±0.15	●
5.50	310	GDVK 0550-310	±0.15	●
6.00	310	GDVK 0600-310	±0.15	●
6.50	310	GDVK 0650-310	±0.15	●
7.10	310	GDVK 0710-310	±0.15	●
7.60	310	GDVK 0760-310	±0.15	●
8.10	310	GDVK 0810-310	±0.15	●
8.70	310	GDVK 0870-310	±0.15	●
9.20	310	GDVK 0920-310	±0.15	●

○ limited stock ● stock item ▲ new stock item Other grades and dimensions upon request

Rods

Profiled rods with two coolant hole, 115°, fine grain grades

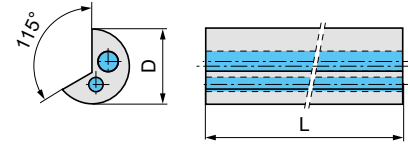

Technical drawings upon request

D [mm]	L [mm]	Type, description	Dia. tol. [mm]	CTF12E
13.50	310	GDV2 1350/115-310	±0.20	○
13.90	310	GDV2 1390/115-310	±0.20	○
14.50	310	GDV2 1450/115-310	±0.20	●
15.50	310	GDV2 1550/115-310	±0.20	●
16.50	310	GDV2 1650/115-310	±0.20	●
17.50	310	GDV2 1750/115-310	±0.20	●
18.60	310	GDV2 1860/115-310	±0.20	●
19.60	310	GDV2 1960/115-310	±0.25	●
20.60	310	GDV2 2060/115-310	±0.25	●
21.60	310	GDV2 2160/115-310	±0.25	●

○ limited stock ● stock item ▲ new stock item Other grades and dimensions upon request

Rods

Profiled rods with two coolant hole, 120°, fine grain grades

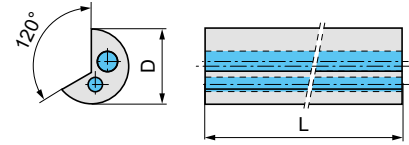

Technical drawings upon request

D [mm]	L [mm]	Type, description	Dia. tol. [mm]	CTF12E
5.50	310	GDV2 0550-310	±0.15	○
6.00	310	GDV2 0600-310	±0.15	○
6.50	310	GDV2 0650-310	±0.15	●
7.10	310	GDV2 0710-310	±0.15	●
7.60	310	GDV2 0760-310	±0.15	●
8.10	310	GDV2 0810-310	±0.15	●
8.70	310	GDV2 0870-310	±0.15	●
9.20	310	GDV2 0920-310	±0.15	●
9.70	310	GDV2 0970-310	±0.15	●
10.80	310	GDV2 1080-310	±0.15	●
11.30	310	GDV2 1130-310	±0.15	●
11.80	310	GDV2 1180-310	±0.15	●
12.30	310	GDV2 1230-310	±0.15	●
12.80	310	GDV2 1280-310	±0.15	●

○ limited stock ● stock item ▲ new stock item Other grades and dimensions upon request

Tips

Profiled tips with two coolant holes, 115°, fine grain grades

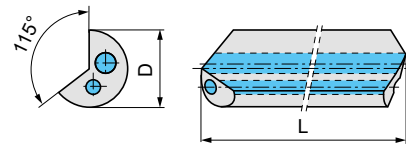

Technical drawings upon request

D [mm]	L [mm]	Type, description	Dia. tol. [mm]	CTF12E
13.50	40	GDV2P 1350-040	±0.20	●
14.50	40	GDV2P 1450-040	±0.20	●
15.50	40	GDV2P 1550-040	±0.20	●
16.50	40	GDV2P 1650-040	±0.20	●
17.50	40	GDV2P 1750-040	±0.20	●
18.60	40	GDV2P 1860-040	±0.25	●
19.60	45	GDV2P 1960-045	±0.25	●
20.60	45	GDV2P 2060-045	±0.25	●
21.60	45	GDV2P 2160-045	±0.25	●
22.60	50	GDV2P 2260-050	±0.25	●
23.60	50	GDV2P 2360-050	±0.25	●
24.60	55	GDV2P 2460-055	±0.25	●
25.60	55	GDV2P 2560-055	±0.25	●
26.60	55	GDV2P 2660-055	±0.25	●
27.20	55	GDV2P 2720-055	±0.25	●
28.70	65	GDV2P 2870-065	±0.25	●
30.80	65	GDV2P 3080-065	±0.25	●
33.10	65	GDV2P 3310-065	±0.25	●
36.10	75	GDV2P 3610-075	±0.25	●
39.10	75	GDV2P 3910-075	±0.25	●
40.00	80	GDV2P 4000-080	±0.30	○
42.00	80	GDV2P 4200-080	±0.30	●
45.00	80	GDV2P 4500-080	±0.30	○

○ limited stock ● stock item ▲ new stock item Other grades and dimensions upon request

Flat and square strips, brazing tips

Our flat and square strips, in the proven CTS20D grade and in a wide variety of dimensions, are available directly from stock. Our brazing tips are characterised by very good brazability and can be supplied upon request in the most common DIN dimensions. Our stock range includes DIN 8011 brazing tips in grade CTS12D, as well as in the cermet grade CTF28T (especially suited to the finish machining of steel materials).

Of course we can also produce carbide rods in other dimensions and grades to order – just get in touch with your contact person at CERATIZIT.

Detailed technical data for our flat and square strips can be found in the 'Information' section.

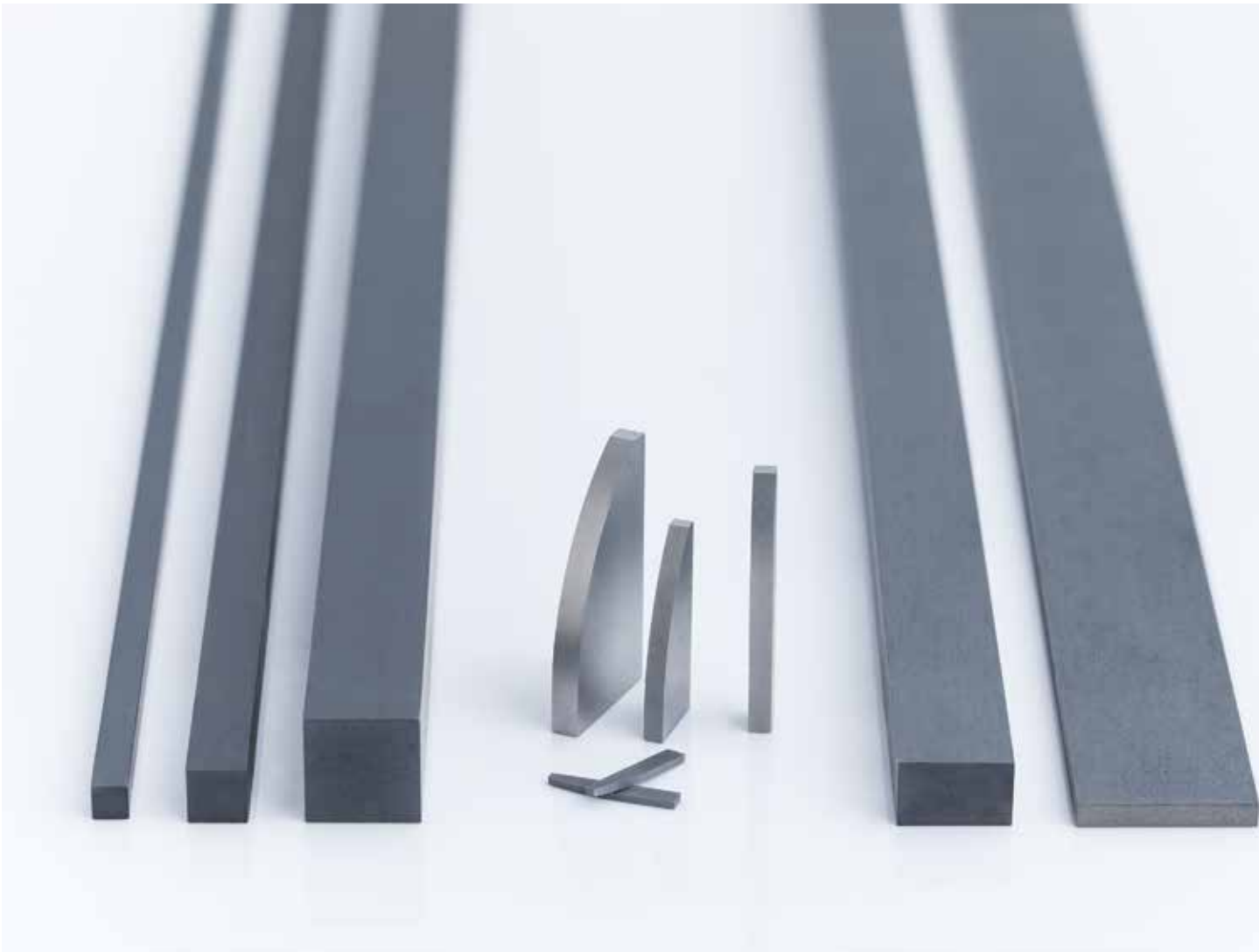

Flat strips

Submicron grade

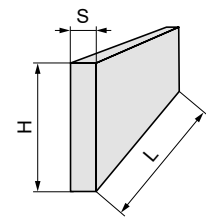

Type, description	H [mm]	S [mm]	L [mm]	CTS20D
FR 0230/0530-330	5.30	2.30	330	●
FR 0230/0630-330	6.30	2.30	330	●
FR 0230/0830-330	8.30	2.30	330	●
FR 0230/1030-330	10.30	2.30	330	●
FR 0230/1630-330	16.30	2.30	330	●
FR 0330/0430-330	4.30	3.30	330	●
FR 0330/0530-330	5.30	3.30	330	●
FR 0330/0630-330	6.30	3.30	330	●
FR 0330/0830-330	8.30	3.30	330	●
FR 0330/1030-330	10.30	3.30	330	●
FR 0330/1230-330	12.30	3.30	330	●
FR 0330/1630-330	16.30	3.30	330	●
FR 0330/2030-330	20.30	3.30	330	●
FR 0430/0630-330	6.30	4.30	330	●
FR 0430/0830-330	8.30	4.30	330	●
FR 0430/1030-330	10.30	4.30	330	●
FR 0430/1330-330	13.30	4.30	330	●
FR 0430/1630-330	16.30	4.30	330	●
FR 0430/2030-330	20.30	4.30	330	●
FR 0530/1030-330	10.30	5.30	330	●
FR 0530/1330-330	13.30	5.30	330	●
FR 0630/1030-330	10.30	6.30	330	●
FR 0630/1330-330	13.30	6.30	330	●
FR 0830/1230-330	12.30	8.30	330	●
FR 0830/1630-330	16.30	8.30	330	●
FR 1030/1630-330	16.30	10.30	330	●

○ limited stock ● stock item ▲ new stock item Other grades and dimensions upon request

Square strips

Submicron grade

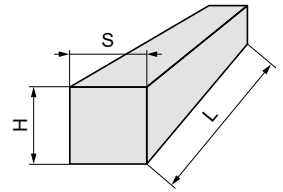

Type, description	H [mm]	S [mm]	L [mm]	CTS20D
SR 0330-330	3.30	3.30	330	●
SR 0430-330	4.30	4.30	330	●
SR 0530-330	5.30	5.30	330	●
SR 0830-330	8.30	8.30	330	●
SR 1030-330	10.30	10.30	330	●

○ limited stock ● stock item ▲ new stock item Other grades and dimensions upon request

Brazing tips to DIN 8011

Form R

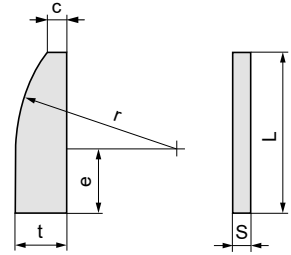

Type, description	L [mm]	e [mm]	S [mm]	r [mm]	c [mm]	t [mm]	CTF28T	CTS12D
DIN 8011 R 12	12	5.00	0.80	25.00	0.80	2.00	●	○
DIN 8011 R 16	16	7.10	1.20	25.00	1.00	2.50	●	●
DIN 8011 R 19	19	9.00	1.40	25.00	1.00	3.00	●	●
DIN 8011 R 22	22	11.20	1.80	25.00	1.40	3.50	●	●
DIN 8011 R 25	25	15.00	2.20	25.00	1.40	4.00	●	●
DIN 8011 R 30	30	18.00	2.80	25.00	1.40	5.00	●	●

Brazing tips to DIN 8011

Form T

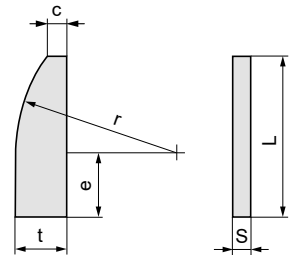

Type, description	L [mm]	e [mm]	S [mm]	r [mm]	c [mm]	t [mm]	CTS12D
DIN 8011 T 12	12	4.50	1.20	15.00	1.00	3.00	○
DIN 8011 T 16	16	7.50	1.60	15.00	1.00	3.50	○
DIN 8011 T 19	19	7.50	2.00	25.00	1.80	4.50	●
DIN 8011 T 22	22	9.50	2.50	25.00	2.50	5.60	●
DIN 8011 T 25	25	10.00	2.80	25.00	3.00	8.00	●

○ limited stock ● stock item ▲ new stock item Other grades and dimensions upon request

Brazing tips to DIN 8011

Form U

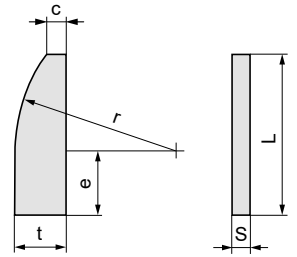

Type, description	L [mm]	e [mm]	S [mm]	r [mm]	c [mm]	t [mm]	CTS12D
DIN 8011 U 12	12	1.40	1.20	15.00	1.00	5.60	○
DIN 8011 U 16	16	4.00	1.60	15.00	1.00	6.70	○
DIN 8011 U 19	19	2.50	2.00	25.00	1.80	8.00	●
DIN 8011 U 22	22	2.80	2.50	25.00	2.50	11.20	●
DIN 8011 U 25	25	4.00	2.80	25.00	3.00	14.00	●

○ limited stock ● stock item ▲ new stock item Other grades and dimensions upon request



Special products

In addition to our standard programme we also offer individual solutions for our rods. Thanks to our comprehensive manufacturing possibilities we can also implement your most demanding requirements. Whether special coolant hole profiles, large helix angles or other customised versions, see for yourself and benefit from our expertise.

In our up-to-date grinding department we also produce semi-finished ground articles, in high volumes as well as in small batches.



Available types



- ▲ Broad selection of diameters and grades starting at 0.40 mm, e.g. for erosion electrodes up to 80 mm for special tools. For semi-finished tools bigger than that we offer customised preforms.



- ▲ Solid carbide or coolant hole rods up to a metre in length are no problem for us. Close tolerance production techniques of spiral through hole rod minimise the risk of grinding through into the coolant channels. Using leading-edge technologies we are also able to deliver coolant hole rod with pre-formed flutes if required.



- ▲ Increasingly, tool producers rely on prefabricated semi-finished products. In this context we offer ground cut-to-lengths in a variety of versions. For example steps, tapers, cones, male or female centres, ball noses, chamfers, recesses, ground holes and many others.



- ▲ Thanks to our modern extrusion processes we can offer you a variety of coolant hole profiles.

Preforms

In addition to our comprehensive range of rods we also offer various types of preforms for rotary cutting tools. The products include both blanks and semi-finished tools for solid carbide and PCD tools, exchangeable head systems and tool shanks. Years of experience in the field of blank machining combined with a state-of-the-art production plant make it possible for us to produce the most complex, near net shape geometries with short delivery times. In particular for tool shanks and PCD tool bodies we have developed the new grade CTF25E which is ideal even for the most sophisticated tool versions with narrow shapes and critical transitions.



Available types

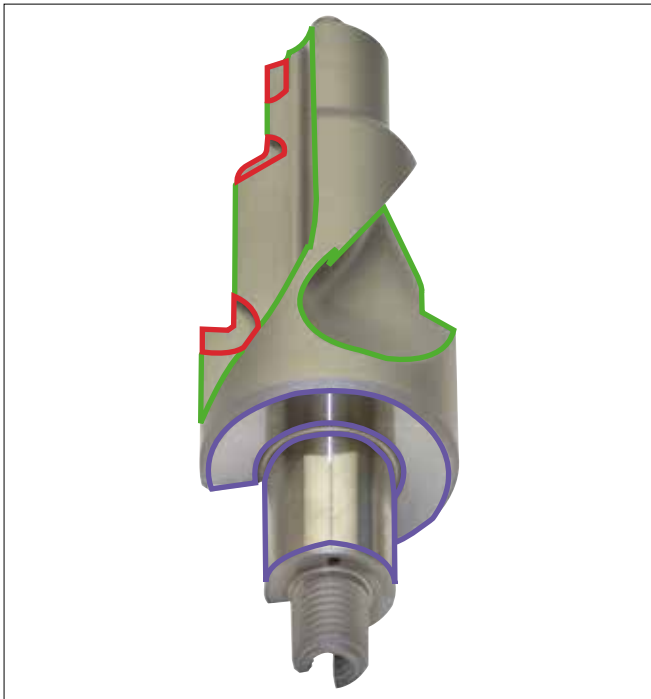

Based on your drawings of blanks or finished parts, we are able to produce outside diameters of up to approx. 300 mm and lengths of approx. 500 mm. Ideally, you should provide us with digital drawings or 3-D models (.stp, .prt,....).

- ▲ Diameter as sintered up to around 500 mm
- ▲ Lengths up to around 300 mm

- Preformed seats for PCD inserts
- Straight and helical chip flutes
- Ground shanks

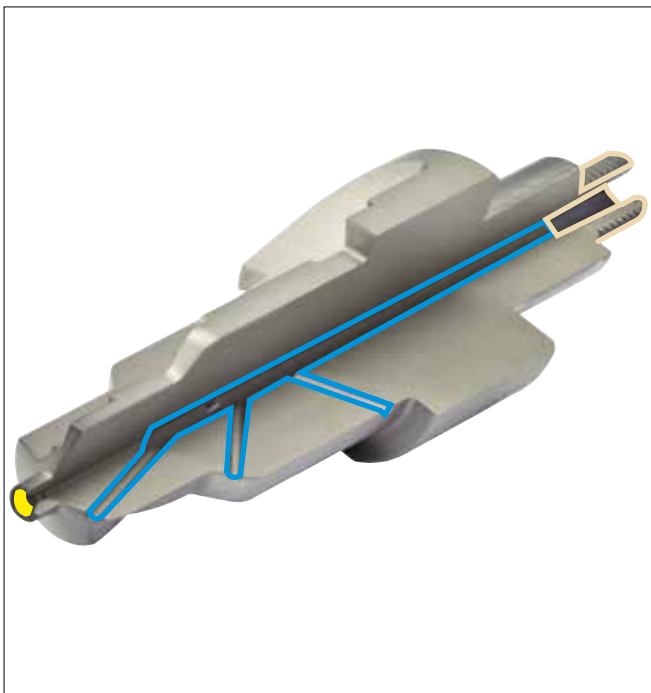

- External and internal thread
- Coolant holes
- As sintered male or female centres



Our preformed chip flutes and insert seats with optimised machining allowance make it possible to save production costs thanks to reduced grinding times in tool production.



Individually designed coolant exit holes can be formed into the blank.

- ▲ Axial holes from \varnothing 0.65 mm
- ▲ Radial exit holes from \varnothing 0.5 mm and greater
- ▲ Smaller holes available depending on the depth and upon request



- ▲ Outside and inside threads
- ▲ Metric ISO threads, as sintered, tolerance class 8H
- ▲ UN threads, as sintered
- ▲ Special threads upon request
- ▲ Ground threads are possible upon request



- ▲ Female and male centres
- ▲ Female centres to DIN 332
- ▲ As sintered centres (form 'R' preferred)
- ▲ Upon request ground version also available



- ▲ Upon request ground version also available, for example ground shank to h6

Do not hesitate to contact us with questions about possible variations. We will be pleased to help you design blanks for cost-efficient production of precision tools.

Grades: composition and properties

An extensive stock of the most important grades makes shortest delivery times for customised blanks possible.

Submicron grade

Grade	ISO code	U.S. code	Binder [m %]	Density [g/cm ³]	Hardness		Transverse rupture strength		K _{IC} (Shetty) [MPa·m ^{1/2}]
					HV30	HRA	[MPa]	[psi]	
CTS12D	K05 – K10	C-3	6.0	14.80	1820	93.1	3600	522.100	9.3
CTS15D	K10 – K30	C-3	7.5	14.70	1750	92.8	3700	536.000	9.5
CTS20D	K20 – K40	C-2	10.0	14.38	1600	91.9	4000	580.100	10.4

Fine grain grade

Grade	ISO code	U.S. code	Binder [m %]	Density [g/cm ³]	Hardness		Transverse rupture strength		K _{IC} (Shetty) [MPa·m ^{1/2}]
					HV30	HRA	[MPa]	[psi]	
CTF25E	K30 – K40	C-2	12.5	14.15	1300	89.5	3500	507.600	15.0

Our CTF25E fine-grain grade has been specially designed for PCD tools and tool shanks.

The coarser grain structure combined with higher cobalt content provides this grade with increased resistance to breakage and excellent brazability.

CTF25E vs. CTS20D

	CTS20D	CTF25E
▲ Grain size:	submicron	fine grain
▲ Cobalt content:	10.0%	12.5%
▲ Additives:	1.15%	1.2%
▲ Hardness:	1600 HV30	1300 HV30
▲ Transverse rupture strength:	4000 MPa	3500 MPa
▲ Fracture toughness K _{IC} :	10.4 MPa·m ^{0,5}	15 MPa·m ^{0,5}

CTS20D

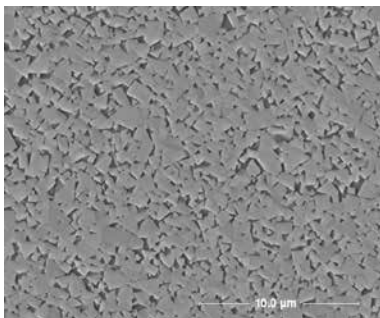

CTF25E

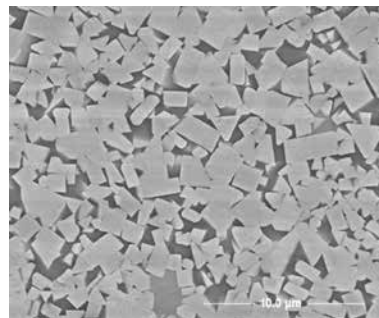

Of course we also offer preforms in all other 'Round Tool Materials' grades upon request.

Specifications



Straightness

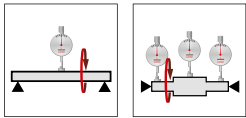

max. deflection
[mm]
0.3

Diameter steps

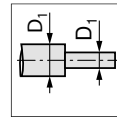

Different diameters, dia. steps
 $D_1 - D_2 \geq 1 \text{ mm}$

Wall thicknesses

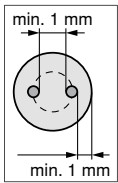

Min. wall thicknesses and hole distances
 $\geq 1 \text{ mm}$

Tolerance table for preforms

Diameters for preforms

Nominal \varnothing [mm]	Blank tolerance incl. grinding allowance [mm]	Sintering tolerance [\pm]
< 20	0.55	± 0.15
> 20 – 35	0.60	± 0.20
> 35 – 45	0.65	± 0.25
> 45 – 55	0.70	± 0.30
> 55 – 70	0.85	± 0.35
> 70 – 100	0.90	± 0.40
> 100 – 150	1.00	± 0.50

Example of a finished diameter 22 mm with grinding allowance:

Finished dimension $\varnothing 22.00 \text{ mm}$
Grinding allowance +0.60 mm
Blank dimensions $\varnothing 22.60 \pm 0.20 \text{ mm}$

Lengths for preforms

Length [mm]	Blank tolerance incl. grinding allowance [mm]	Sintering tolerance [\pm]
L	$0.5\% L + 0.4$	$\pm 0.5\% L$

Example of a finished length 150 mm with grinding allowance:

Finished dimension 150 mm
Grinding allowance +1.15 mm
Blank dimensions $151.15 \pm 0.75 \text{ mm}$

→ For further information go to page 93.



Information

In this section you can find additional information on product labelling, technical product specifications and carbide properties. Specifications for preforms can be found at the end of the 'Preforms' section.



Product labelling

Material short text:

The material short text describes the article in terms of the most important geometrical specifications.
A guide to the designation system can be found in the catalogue on page 20.

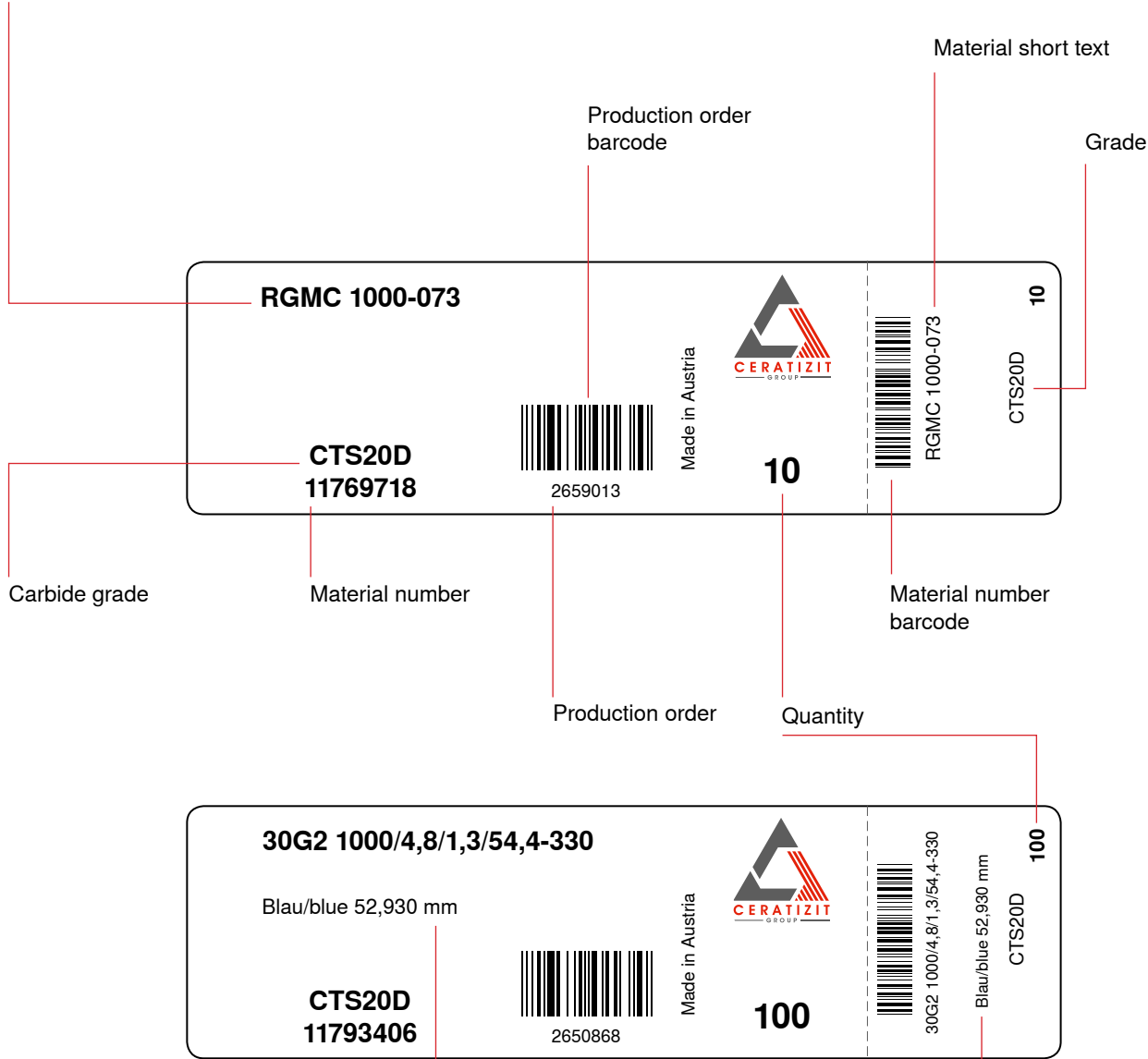

Pitch information:

(for rods with helical coolant holes)

The pitch class and its average value are stated. This value acts as the adjustment value for flute grinding.
More information on the pitch classification for rods with helical coolant holes can be found in the catalogue on page 92.

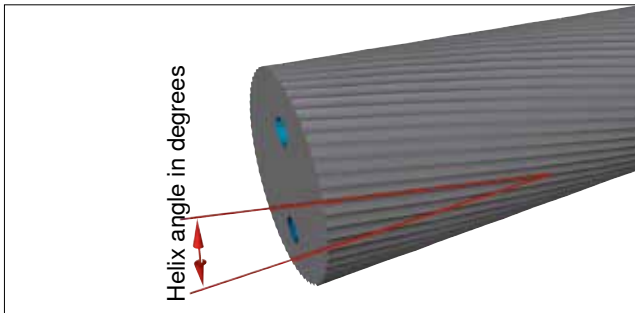

Definition of the helix angle

The helix angle indicates the torsion of the coolant holes in relation to the nominal diameter. In this context it has to be taken into account that the angle decreases depending on the diameter steps. For this reason, rods with 40° coolant holes are used for step drills in order to achieve an optimal spiral flute helix angle of 25 to 30°.

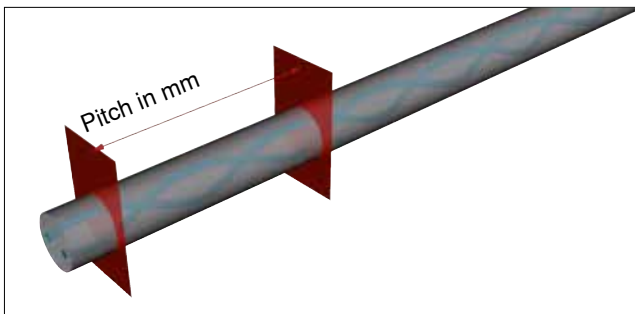

Definition of pitch

The pitch is the length of a complete 360° rotation of the coolant holes. This value is independent of the diameter or the diameter steps. The CERATIZIT designation system for coolant hole rods includes both the helix angle in degrees and the pitch of the helix in millimetres.

Conversion helix angle/pitch:

Conversion pitch to angle: $\alpha = \tan^{-1} \frac{d \times \pi}{Stg}$

Conversion angle to pitch: $Stg = \frac{d \times \pi}{\tan \alpha}$

- Stg. pitch
- d nominal diameter
- α helix angle

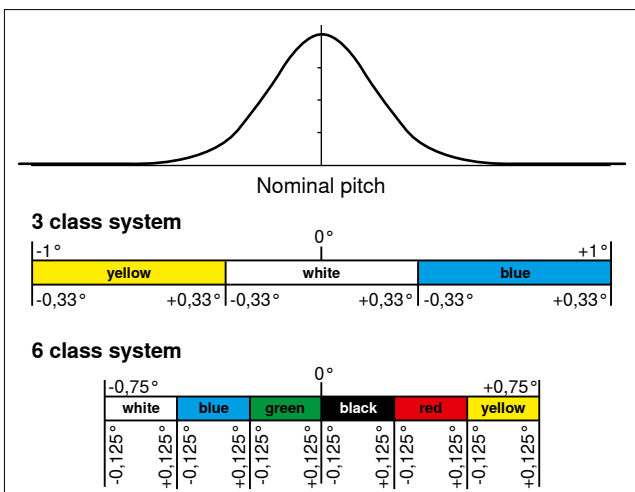

Pitch classification

In order to guarantee closest pitch tolerances our carbide rods with helical coolant holes are divided into tolerance classes. For this purpose all rods are measured and assigned to the respective class, which is indicated on the product label. For details of our pitch classification see page 98.

Outside diameter

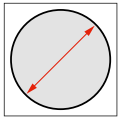

Measured outside diameter of the round rod. In case of helical coolant hole rods the 'outside diameter' means the OD (addendum diameter) including the helical tooling grooves.

Length

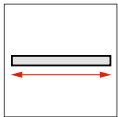

Measured length of the round rod.

Surface

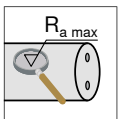

The surface quality describes the state of the surface. For ground rods the surface value is indicated as maximum average roughness value R_a (DIN EN ISO 4287:1998).

Straightness

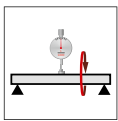

Maximum deflection of a rotating rod which lies on two contact points, measured in the middle of the rod. The distance between the two contact points is 300 mm. When the rod is longer or shorter than 330 mm the contact width corresponds to the rod length minus 10 mm.

Concentricity

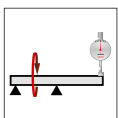

Maximum deflection of a rod. Contact point A is 5 mm before the chamfer. Contact point B is in the middle of the rod. The measurement is carried out 2 mm from the end.

Cylindricity

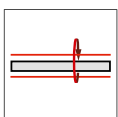

The cylindricity describes the tolerance field of an ideal cylinder inside which the skin surface of the rod should be.

Width, height

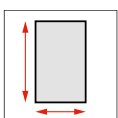

Lateral length of flat and square strips

Roundness

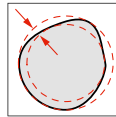

Roundness is the radial distance of two concentric circles which include the circumference line of the round rod's section. (DIN ISO 1101).

Pitch circle diameter

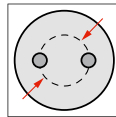

The pitch circle is defined as the circle which goes through two or three centre points of coolant holes.

Hole diameter

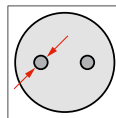

The hole diameter is the diameter of the coolant holes inside the rod.

Excentricity

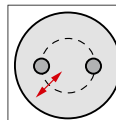

Excentricity means the deviation of the pitch circle centre point or, in case of a coolant hole, the deviation of the coolant hole centre point from the centre point of the rod.

Helix angle

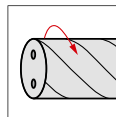

The helix angle is the angle between the longitudinal axis and the helix line.

Torsion

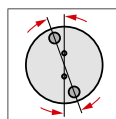

Maximum difference of the angle of the two imaginary lines which go through the centre point of the coolant holes which are on the pitch circle.

Pitch error

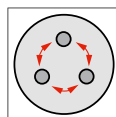

For rods with three helical coolant holes the section surface is divided into three circle sectors which go through the centre point of the coolant holes. The pitch error is the difference of the angles between the circle sectors.

Solid carbide rods



Outside diameter

as sintered

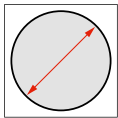

Outside diameter [mm]	Tolerance [mm]
0.8 – 2.1	+0/+0.15
2.2 – 4.7	+0/+0.20
4.8 – 6.7	+0/+0.25
6.8 – 15.2	+0/+0.30
15.3 – 20.2	+0/+0.45
20.3 – 24.2	+0/+0.55
24.3 – 36.2	+0/+0.65
36.3 – 46.2	+0/+0.70

ground

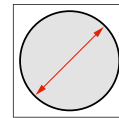

Outside diameter [mm]	Tolerance [mm]	
	h6 [mm]	h5 [mm]
1.0 – 3.0	+0/-0.006	+0/-0.004
3.1 – 6.0	+0/-0.008	+0/-0.005
6.1 – 10.0	+0/-0.009	+0/-0.006
10.1 – 18.0	+0/-0.011	+0/-0.008
18.1 – 30.0	+0/-0.013	+0/-0.009
30.1 – 40.0	+0/-0.016	+0/-0.011

Straightness

as sintered

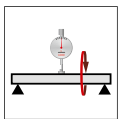

Outside diameter [mm]	max. deflection [mm]
0.8 – 3.2	1.2
3.25 – 46.2	0.5

ground

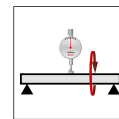

Outside diameter [mm]	max. deflection [mm]
1.0 – 2.9	1.20
3.0 – 5.9	0.15
6.0 – 7.9	0.12
8.0 – 9.9	0.10
10.0 – 11.9	0.08
12.0 – 19.9	0.05
20.0 – 40.0	< 0.05

Roundness

as sintered

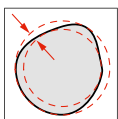

Outside diameter [mm]	Tolerance [mm]
0.8 – 5.7	0.05
5.8 – 7.7	0.08
7.8 – 12.7	0.10
12.8 – 30.2	0.13
30.3 – 46.2	0.16

ground

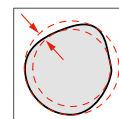

Outside diameter [mm]	Tolerance [mm]	
	h6 [mm]	h5 [mm]
1.0 – 3.0	0.003	0.003
3.1 – 6.0	0.004	0.003
6.1 – 10.0	0.005	0.003
10.1 – 30.0	0.006	0.004
30.1 – 40.0	0.008	0.005

Surface finish

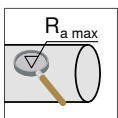

Executions	Ra _{max} [μm]
as sintered	as sintered
ground	0,05

Length

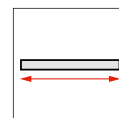

Tolerance [mm]
+0/+10

End mill blanks



Outside diameter

Outside diameter [mm]	Tolerance	
	h6 [mm]	h5 [mm]
1.0 – 3.0	+0/-0.006	+0/-0.004
3.1 – 6.0	+0/-0.008	+0/-0.005
6.1 – 10.0	+0/-0.009	+0/-0.006
10.1 – 18.0	+0/-0.011	+0/-0.008
18.1 – 30.0	+0/-0.013	+0/-0.009
30.1 – 40.0	+0/-0.016	+0/-0.011

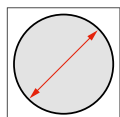

Surface finish

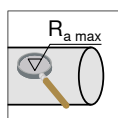

Ra _{max} [μm]
0.05

Length

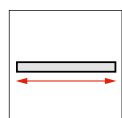

Type	Total length tolerance [mm]
RGMC	+1%
RGIC	+1.5%

Roundness

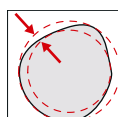

Outside diameter [mm]	Tolerance	
	h6 [mm]	h5 [mm]
1.0 – 3.0	+0/+0.003	+0/+0.002
3.1 – 6.0	+0/+0.003	+0/+0.002
6.1 – 10.0	+0/+0.003	+0/+0.002
10.1 – 25.0	+0/+0.004	+0/+0.002

Run-out RGMC

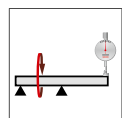

Outside diameter [mm]	max. concentricity [μm] starting length [mm]									
	30	40	50	60	70	80	90	110	140	
3.0	5	5	6	7	-	-	-	-	-	
4.0 – 5.0	5	5	6	6	7	-	-	-	-	
6.0	4	5	5	6	6	7	8	-	-	
8.0 – 10.0	4	4	4	5	5	5	6	7	-	
12.0 – 14.0	3	4	4	4	4	5	5	6	-	
16.0 – 20.0	3	4	4	4	4	4	5	5	6	
25.0	3	4	4	4	4	4	5	5	6	

Run-out RGIC

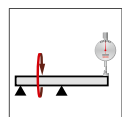

Outside diameter [inch]	maximum concentricity [μm] starting length [inch]		
	1.500 – 2.500	2.501 – 3.500	3.501 – 8.000
1/8 – 3/16	5	7,6	-
1/4 – 1	5	7,6	10

Drill blanks

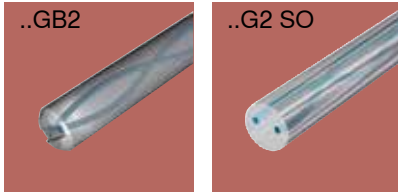

Pitch circle diameter of DIN drill blanks

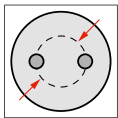

Pitch circle diameter [mm]	Tolerance [mm]
1.6 – 6.3	+/-0.20
6.7 – 8.0	+/-0.25
9.0 – 10.0	+/-0.30

Pitch circle diameter for micro-drill blanks

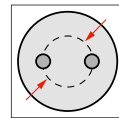

Pitch circle diameter [mm]	Tolerance [mm]
0.29	+/-0.03
0.30 – 1.05	+/-0.05
1.06 – 2.0	+/-0.08

Helix angle for DIN drill blanks

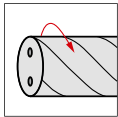

Total tolerance class [°]	Number of classes	Tolerance class [°]
+/-1	3	+/-0.33

Helix angle for micro-drill blanks

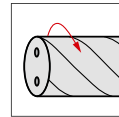

Total tolerance class [°]	Number of classes	Tolerance class [°]
+/-0.75	6	+/-0.125

Straightness of DIN drill blanks

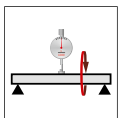

Outside diameter [mm]	Deflection [µm] with length [mm]					
	63-66	67-81	82-114	115-133	134-162	163-310
6.0	10	15	30	40	-	-
8.0	-	15	20	40	40	-
10.0	-	-	20	30	40	50
12.0	-	-	20	30	30	50
14.0	-	-	20	30	30	50
16.0	-	-	-	20	30	50
18.0	-	-	-	20	30	50
20.0	-	-	-	20	30	50

Run-out of micro-drill blanks

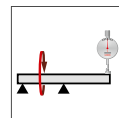

Outside diameter [mm]	Deflection [µm] with length [mm]			
	55-65	66-85	86-105	106-180
3.0	5	8	20	20
4.0	-	8	15	20

Excentricity of DIN drill blanks

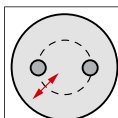

Pitch circle diameter [mm]	max. excentricity [mm]
1.6 – 3.4	0.10
4.8	0.15
6.3 – 6.7	0.18
8.0 – 10.0	0.20

Excentricity of micro-drill blanks

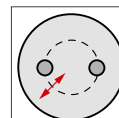

Pitch circle diameter [mm]	max. excentricity [mm]
0.29	0.025
0.30 – 0.59	0.035
0.6 – 1.5	0.040
1.51 – 2.00	0.050

Outside diameter

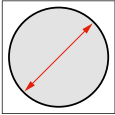

Outside diameter [mm]	Tolerance h5 [mm]
3.0	+0/-0.004
3.1 – 6.0	+0/-0.005
6.1 – 10.0	+0/-0.006
10.1 – 18.0	+0/-0.008
18.1 – 30.0	+0/-0.009

Length

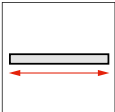

Tolerance
+0%/+1%

Hole diameter

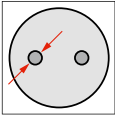

Hole diameter [mm]	Tolerance [mm]
0.05	+/-0.010
0.06 – 0.20	+/-0.015
0.21 – 0.45	+/-0.030
0.5 – 1.3	+/-0.050
1.31 – 2.50	+/-0.075

Surface finish

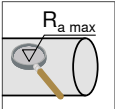

Product	Ra _{max} [μm]
DIN drill blanks	Ground mat, 0.05 - 0.1
Micro-drill blanks	0.05

Roundness

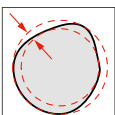

Outside diameter [mm]	Tolerance [mm]
3.0 – 6.0	0.002
8.0 – 10.0	0.003
12.0 – 18.0	0.004
20.0	0.005

Cross groove profile for DIN drill blanks

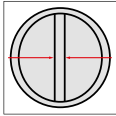

Outside diameter [mm]	Cross groove width [mm]	Cross groove depth [mm]
6	1.5 +/-0.1	0.30 +/-0.05
8	1.5 +/-0.1	0.40 +/-0.05
10	2.0 +/-0.1	0.50 +/-0.10
12	2.0 +/-0.1	0.60 +/-0.10
14	2.5 +/-0.1	0.80 +/-0.10
16	2.5 +/-0.1	1.10 +/-0.10
18	3.0 +/-0.1	1.30 +/-0.10
20	3.0 +/-0.1	1.60 +/-0.10

Rods with helical coolant holes

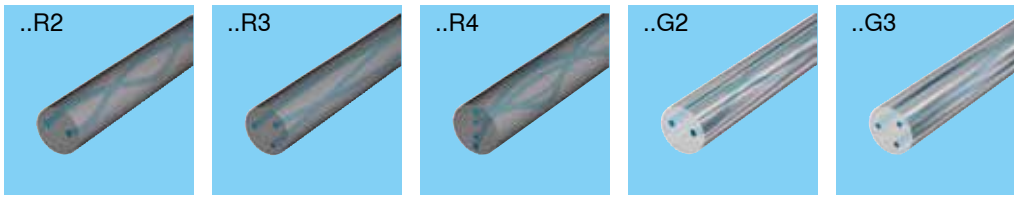

Outside diameter

as sintered

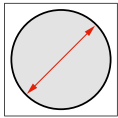

Outside diameter [mm]	Tolerance core diameter [mm]	Tolerance outside diameter [mm]
3.3 – 4.3	+0.10/+0.20	+0.20/+0.60
4.4 – 8.3	+0.10/+0.30	+0.20/+0.70
8.4 – 10.3	+0.10/+0.35	+0.20/+0.75
10.4 – 12.3	+0.10/+0.40	+0.25/+0.80
12.4 – 14.3	+0.10/+0.40	+0.30/+0.80
14.4 – 16.3	+0.10/+0.45	+0.35/+0.95
16.4 – 18.3	+0.10/+0.50	+0.40/+1.00
18.4 – 20.3	+0.10/+0.55	+0.40/+1.05
20.4 – 22.3	+0.10/+0.60	+0.45/+1.10
22.4 – 35.3	+0.10/+0.60	+0.50/+1.10

ground

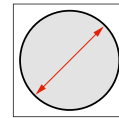

Outside diameter [mm]	Tolerance [mm]
6.0	+0/-0.008
6.1 – 10.0	+0/-0.009
10.1 – 18.0	+0/-0.011
18.1 – 30.0	+0/-0.013
30.1 – 32.0	+0/-0.016

Pitch circle diameter

as sintered

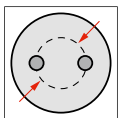

Outside diameter [mm]	Tolerance [mm]
3.3	+/-0.10
3.4 – 4.3	+/-0.15
4.4 – 12.3	+/-0.20
12.4 – 18.3	+/-0.25
18.4 – 35.3	+/-0.30

ground

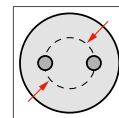

Outside diameter [mm]	Tolerance [mm]
6.0 – 12.0	+/-0.20
12.1 – 18.0	+/-0.25
18.1 – 32.0	+/-0.30

Straightness

as sintered

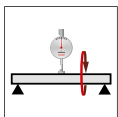

Length [mm]	max. deflection [mm]
250 – 280	0.40
> 280	0.50

ground

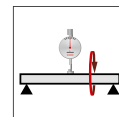

Outside diameter [mm]	max. deflection [mm]
6.0 – 7.9	0.12
8.0 – 9.9	0.10
10.0 – 11.9	0.08
12.0 – 19.9	0.05
20.0 – 32.0	< 0.05

Helix angle

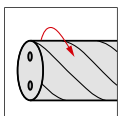

Product group	Total tolerance class [°]	Number of classes	Tolerance class [°]
Standard	+/-1	3	+/-0.333
Ø 3.3 – 4.3	+/-0.75	6	+/-0.125
extra-long, 3 holes	+/-0.75	6	+/-0.125

Length

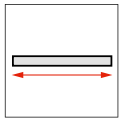

Total length tolerance
[mm]
+0/+10

Hole diameter

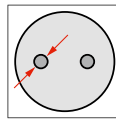

Outside diameter [mm]	Hole diameter [mm]	Tolerance [mm]
3.3 – 4.3	≤ 1.00	+/-0.030
3.3 – 4.3	≥ 1.01	+/-0.050
4.4 – 35.3	0.40 – 1.30	+/-0.050
4.4 – 35.3	1.31 – 2.50	+/-0.075
4.4 – 35.3	2.51 – 5.00	+/-0.100

Surface finish

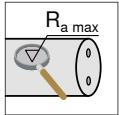

Executions	R _{a max.} [μm]
as sintered	as sintered
ground	0.05

Pitch error

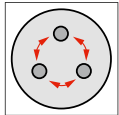

max. pitch error with ..R3
[°]
+/-3.0

Excentricity

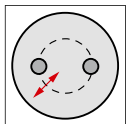

Outside diameter [mm]	Tolerance [mm]
3.3	0.04
3.4 – 4.3	0.05
4.4 – 8.3	0.10
8.4 – 10.3	0.15
10.4 – 14.3	0.18
14.4 – 35.3	0.20

Roundness

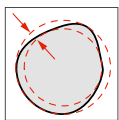

Outside diameter [mm]	Tolerance [mm]
6.0	0.004
6.1 – 10.0	0.005
10.1 – 30.0	0.006
30.1 – 32.0	0.008

Torsion

as sintered

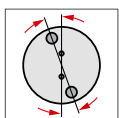

max. torsion with ..R4
[°]
2.0

Rods with straight coolant holes

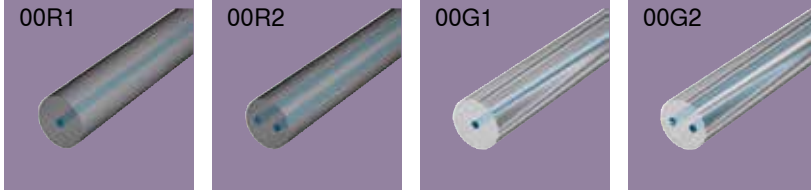

Outside diameter

as sintered

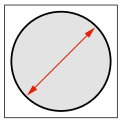

Outside diameter [mm]	Tolerance [mm]
3.3	+0/+0.20
3.4 – 5.0	+0/+0.30
5.1 – 6.5	+0/+0.35
6.6 – 15.2	+0/+0.40
15.3 – 20.7	+0/+0.55
20.8 – 22.2	+0/+0.65
22.3 – 34.3	+0/+0.75

ground

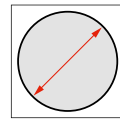

Outside diameter [mm]	Tolerance [mm]
4.0 – 6.0	+0/-0.008
6.1 – 10.0	+0/-0.009
10.1 – 18.0	+0/-0.011
18.1 – 30.0	+0/-0.013
30.1 – 32.0	+0/-0.016

Straightness

as sintered

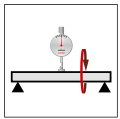

max. deflection [mm]
0.50

ground

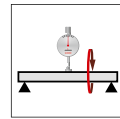

Outside diameter [mm]	max. deflection [mm]
4.0 – 5.9	0.15
6.0 – 7.9	0.12
8.0 – 9.9	0.10
10.0 – 11.9	0.08
12.0 – 19.9	0.05
20.0 – 32.0	< 0.05

Roundness

as sintered

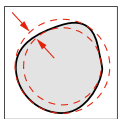

Outside diameter [mm]	Tolerance [mm]
3.3 – 5.7	0.05
6.2 – 7.7	0.08
8.2 – 12.7	0.10
13.2 – 30.2	0.13
30.3 – 34.3	0.16

ground

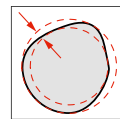

Outside diameter [mm]	Tolerance [mm]
4.0 – 6.0	0.004
6.1 – 10.0	0.005
10.1 – 30.0	0.006
30.1 – 32.0	0.008

Length

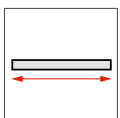

Total length tolerance [mm]
+0/+10

Hole diameter

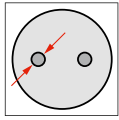

Product group	Hole diameter [mm]	Tolerance [mm]
	0.10 – 0.50	+0.05
central	0.51 – 1.30	+0.10
coolant hole	1.31 – 2.50	+0.15
	2.51 – 5.00	+0.20
	0.10 – 0.50	+/-0.025
two coolant holes	0.51 – 1.30	+/-0.050
	1.31 – 2.50	+/-0.075
	2.51 – 5.00	+/-0.100

Pitch circle diameter

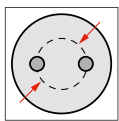

Outside diameter [mm]	Tolerance [mm]
3.3 – 3.9	+/-0.05
4.0 – 5.9	+/-0.10
6.0 – 14.9	+/-0.20
15.0 – 20.9	+/-0.25
21.0 – 34.3	+/-0.30

Surface finish

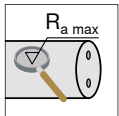

Executions	R _{a max.} [μm]
as sintered	as sintered
ground	0.05

Excentricity

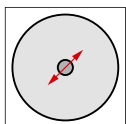

Outside diameter [mm]	Tolerance [mm]
3.3 – 3.9	0.025
4.0 – 5.9	0.050
6.0 – 7.9	0.100
8.0 – 10.9	0.120
11.0 – 24.9	0.150
25.0 – 34.3	0.200

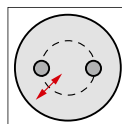

Outside diameter [mm]	Tolerance [mm]
3.3 – 3.9	0.025
4.0 – 5.9	0.050
6.0 – 7.9	0.100
8.0 – 10.9	0.120
11.0 – 24.9	0.150
25.0 – 34.3	0.200

Flat and square strips

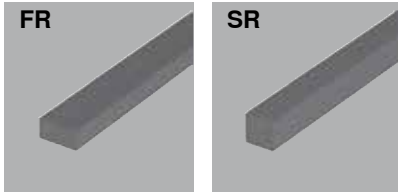

Width, height

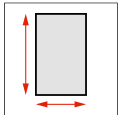

Width, height [mm]	Tolerance [mm]
2.3 – 4.3	+0/+0.20
4.4 – 6.3	+0/+0.25
6.4 – 10.3	+0/+0.30
10.4 – 14.3	+0/+0.35
14.4 – 16.3	+0/+0.40
16.4 – 20.3	+0/+0.50

Levelness

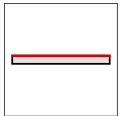

Levelness
[mm]

max. 0.4

Length

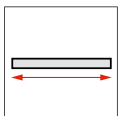

Total length tolerance
[mm]

+0/+10

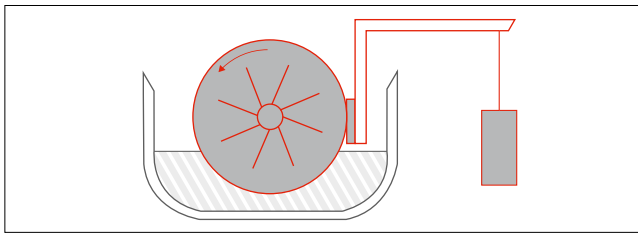

Figure 1: test assembly for the determination of wear resistance according to ASTM B611-85

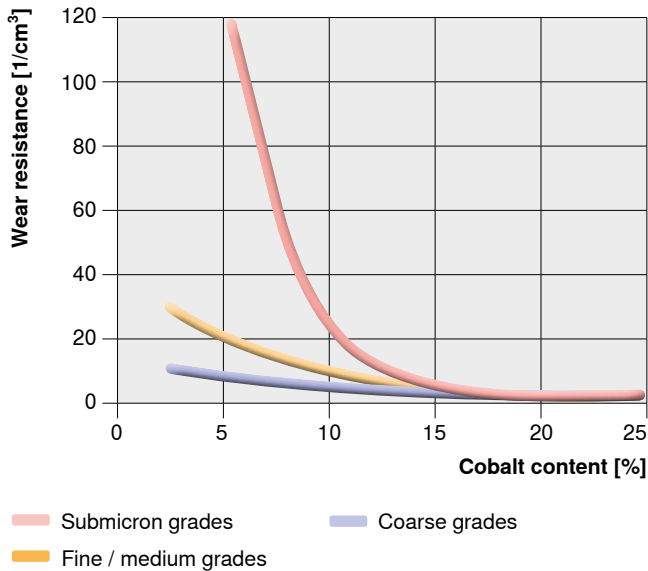

Figure 2: wear resistance in relation to the cobalt content and grain size

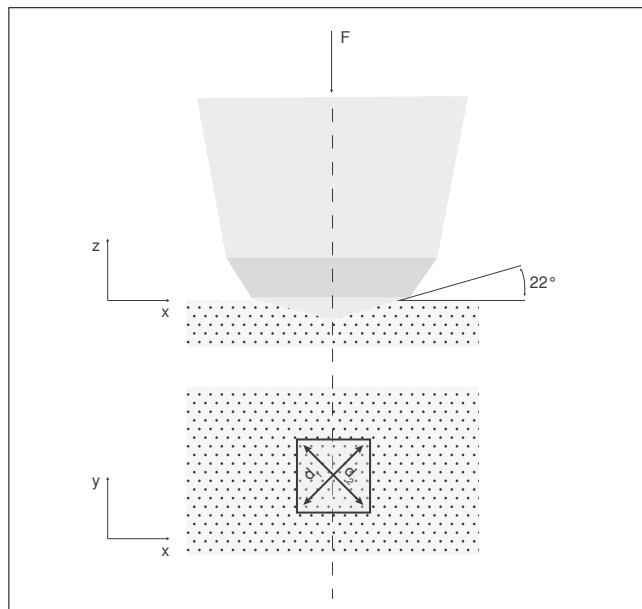

Figure 3: Vickers hardness test according to ISO 3878

$$HV = \frac{0.102 \times 2 \times F \times \sin \frac{136^\circ}{2}}{d^2} \approx 0.1891 \frac{F}{d^2}$$

Formula #1: calculation of the Vickers hardness (ISO 3878)

Mechanical properties of carbide

Wear resistance

The most important property of carbide is wear resistance. This property - or, to be precise, this combination of properties - refers to the surface of the component. When two surfaces rub against each other, material is removed from both of them. Under low stress the material removed consists of single grains or particles. This phenomenon is called 'scoring'. In cases of high stress the material removed consists of grain clusters and is called 'abrasion'. The concept of wear is very complex and depends on many variables. Wear resistance is mainly tested using the ASTM B611-85 method. In this method a carbide piece is pressed onto a rotating steel disk using a lever. The rotating steel disk is the carrier for the abrasive material, which together with the material that is subject to analysis is transported from a tank below the container directly to the contact zone (see figure 1). The abrasive material consists of water and aluminium oxide (corundum). Wear resistance is determined by measuring the volume of material removed from the carbide piece while the revolution number, test time and the force applied at 90° on the steel disk are held at consistent levels. A gravimetric evaluation is carried out, with the volume removal indicated in mm³. As shown in figure 2, wear resistance increases the finer the grain and the lower the cobalt content.

Hardness

Hardness is a material's mechanical resistance to another, harder, material which penetrates it. The hardness is normally determined based on the Vickers hardness test according to ISO 3878. In this test a 136° pyramidal diamond indenter is pressed onto a work piece with a determined test force. The size of the indent is determined optically by measuring the two diagonals of the square indent produced by the applied force (F). The impression surface is calculated with formula #1 (see fig. 3). When introducing this test method the obsolete unit 'kilopond' was used for the test force. Therefore in the formula the factor 0.102 is used for conversion. The standardised indication of the Vickers hardness, for example, is as follows:

620 HV 30

Parameters:

- 620 = hardness
- HV = test procedure
- 30 = test force in kilopond

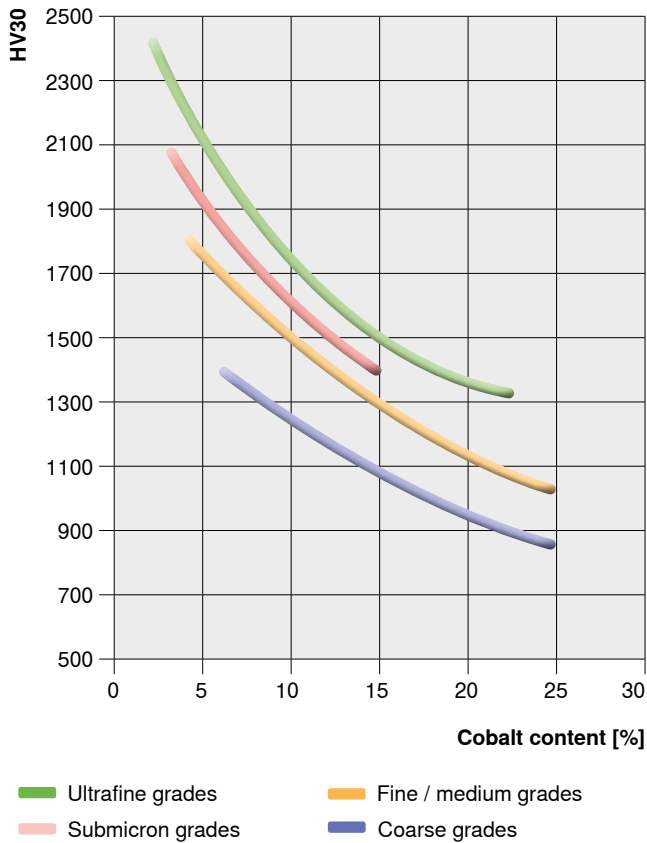

Figure 4: hardness in relation to the cobalt content and grain size

Another method for determining hardness is the Rockwell procedure (ISO 3738). It is similar to the Vickers procedure but uses a diamond brale indenter. Here, the depth of penetration is used as the degree of hardness. There is no theoretical basis for a conversion between the two procedures. In order to create a comparison a determinate test must be carried out. Like wear resistance, hardness also increases with a smaller grain size and lower cobalt content (see figure 4). As wear resistance and hardness show similar behaviour with regard to cobalt content and grain size, hardness is often used as a reference for wear resistance. Furthermore, the Vickers procedure is easier and quicker than ASTM B611-85. Nevertheless the relation of hardness and wear resistance is exponential and also depends on the grain size (see figure 5).

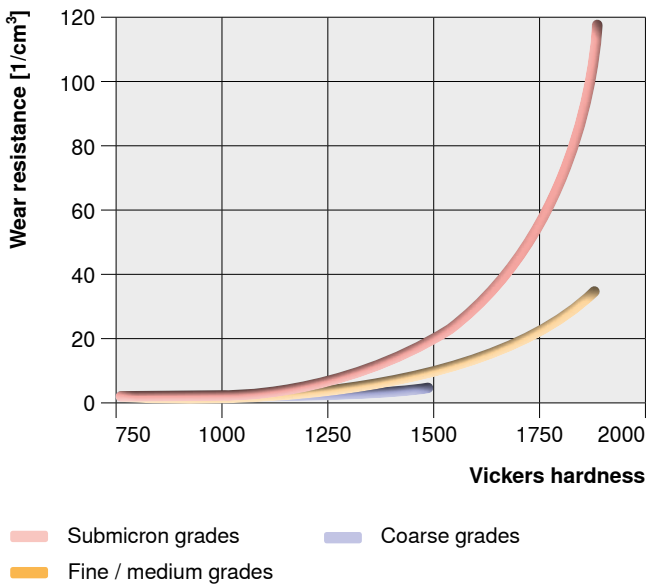

Figure 5: wear resistance in function of hardness with different grain sizes

$$K_{IC} = 0.15 \sqrt{\frac{HV30}{\sum L}} \left[\frac{MN}{m^{\frac{3}{2}}} \right]$$

Formula 2: calculation of the critical tension intensity factor K_{IC}

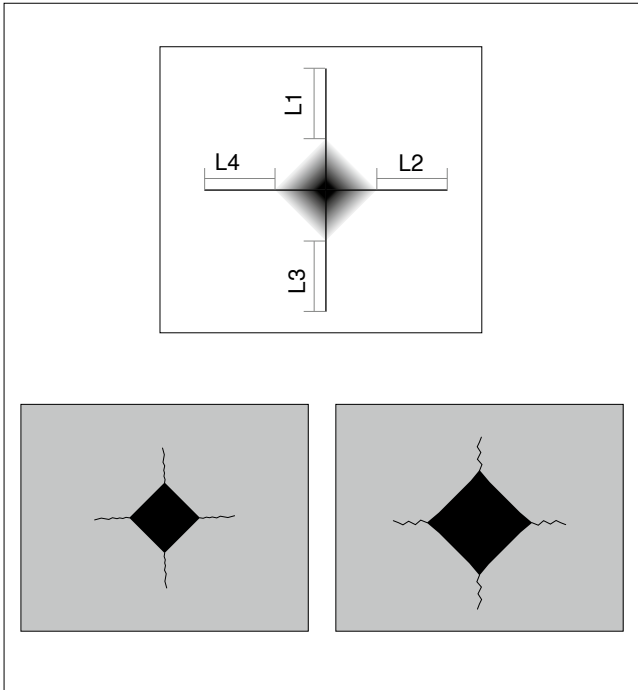

Figure 6: Palmqvist method for the determination of fracture toughness

Toughness

When a material is exposed to external static or dynamic stress, this leads to mechanical tensions. In many cases, particularly with impact loads, both the strength and ductility of the material have to be taken into account. These two properties represent the basis for the concept of toughness, which is defined as the capacity to resist fracture or crack propagation. Fracture in this context means the complete separation of the material into at least two parts. There are numerous possibilities to define or determine toughness, transverse rupture strength or fracture toughness. In the definition above, the integrated product of force and deformation until fracture occurs is used as the toughness value. In the case of carbide, the Palmqvist method is frequently applied to determine the toughness as a critical tension intensity factor K_{IC} . For this purpose, the crack length of a Vickers hardness indent is used to deduce the fracture toughness (see figure 6). This is then converted into the tension intensity factor using formula 2. As can be seen in figure 7, toughness increases with the metal binder content and growing grain size. Compared to other metal materials, carbide can be found in the lower part of the toughness range, about the same as hardened steel.

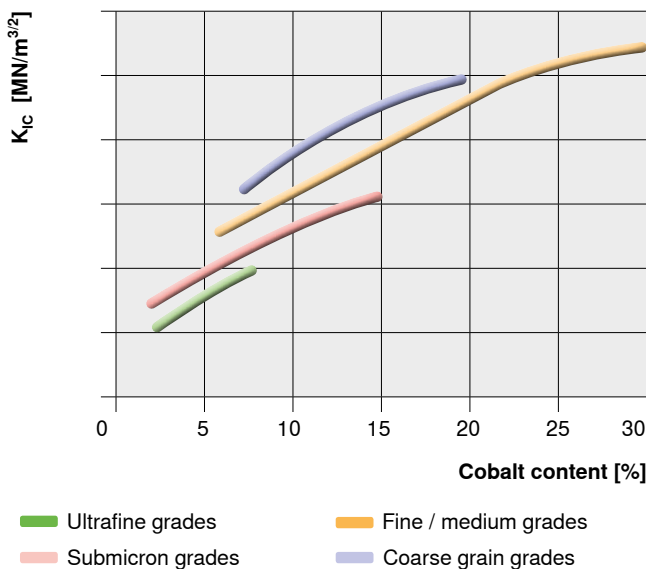

Figure 7: fracture toughness in relation to the grain size and the cobalt content

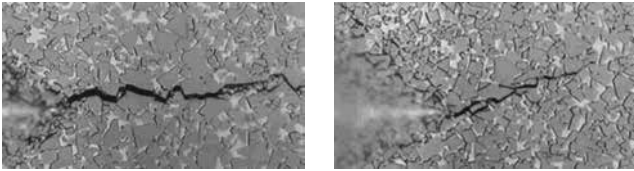

Figure 8: crack propagation in large grain sizes; larger crack propagation requires higher fracture energy - higher toughness

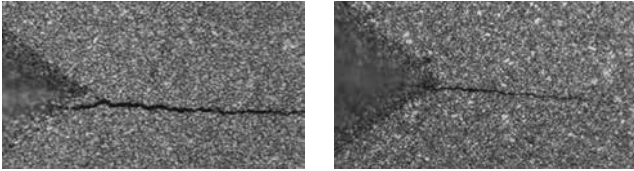

Figure 9: crack propagation in small grain sizes; direct, shorter crack propagation - requires lower fracture energy - lower toughness

By definition, carbide is to be considered a brittle material as there is basically no plastic deformation prior to fracture. This is confirmed by examination of surfaces where breakage occurred. Various carbides, however, show very big differences in terms of toughness which can be best explained by taking a look at the microstructure. Cracks inside the carbide grains may occur just like intergranular fractures and shear fractures in the binder metal. Generally the number of grain cracks rises with increasing grain size and the number of shear fractures when raising the binder content. In terms of fracture energy, the main contribution to toughness comes from the length of the rupture in the metal binder (see figures 8 and 9).

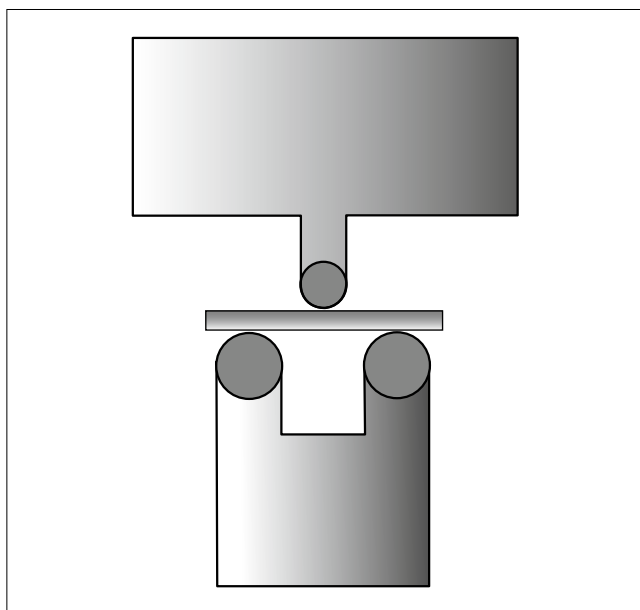

Figure 10: illustration of a transverse rupture strength test

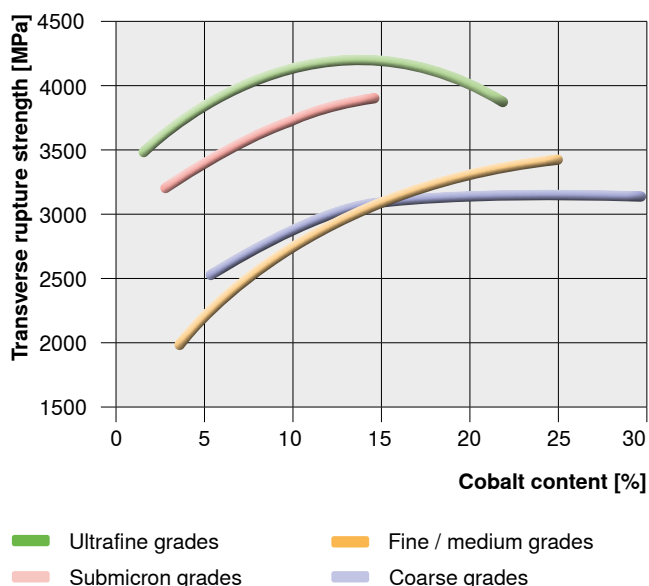

Figure 11: transverse rupture strength in relation to the grain size and the cobalt content

Mechanical strength

Every material has defects such as inclusions and micro-cracks. For brittle materials such as hardened steels or carbide the mechanical strength is limited by the number and size of these defects. In this context the mechanical strength depends on the volume, as with a growing material volume the probability of a large defect rises. Depending on the type of stress, various types of strength are distinguished.

Transverse rupture strength

Testing the transverse rupture strength is the easiest and most common procedure of analysing the mechanical strength of carbide. According to the standardised ISO 3327 procedure a test material of a certain length is placed on a surface and put under stress in the middle until it breaks (see figure 10). The transverse rupture strength (T.R.S.) is then the average value of several tests. The maximum value is achieved with a cobalt content of around 14 weight-% and grain sizes of around 0.2 – 0.5µm.

The very low plastic deformation is normally not taken into account as it occurs only in the toughest carbides. Transverse rupture strength decreases with increasing temperature.

Furthermore, the carbides show creep values when they are subjected to stress or to high temperatures for a long time. The transverse rupture strength is decisively influenced by the number and size of defects in the structure or on the surface. Fractures always occur at the weakest point of the structure, which is also where the largest defect is. A high number of defects therefore increases the probability that one of these defects causes a premature fracture on the point with the highest stress. As the quality demands in the field of carbide manufacturing are high, impurities or defects can be minimised and thus the risk of breakage reduced.

Tensile strength

When testing the tensile strength of brittle materials it is difficult to measure exact results. A precise result depends on both the perfect preparation of the test materials as well as on the additional stress present on the mounting fixtures. Applying the Weibull theory, however, the tensile strength can be deduced from the values of the transverse rupture strength.

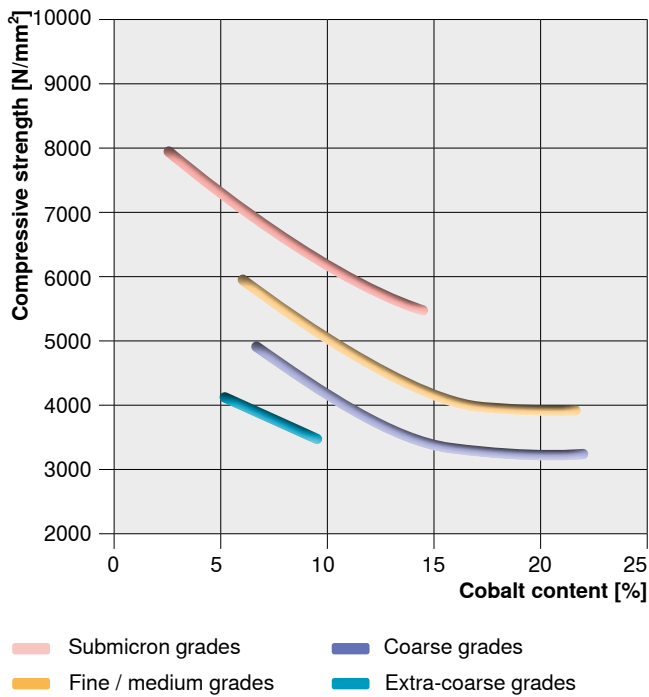

Figure 12: compressive strength in relation to the grain size and the cobalt content

Compressive strength

One of the most remarkable properties of carbide is the extremely high compressive strength under uniaxial stress. This valuable property is used in virtually all application fields (cutting edges with high compressive strength in all machining processes, pressing and drawing dies, rolls, anvils and dies for the production of synthetic diamonds, etc.). The tension of this kind of stress doesn't actually cause fracture due to pressure but due to tension: a shear fracture. A suitable procedure for determining compressive strength can be found in ISO 4506. To achieve precise values for carbide, the test piece's geometry must be changed so that the effects of the edges and contact, which occur in a simple cylindrical test piece, are eliminated. Elastic deformation is produced under initial load; however, before fracture a degree of plastic deformation results. Figure 12 shows the compressive strength of various grain sizes in relation to the cobalt content.

The compressive strength increases when the metal binder content decreases and the grain size is reduced. A small grain carbide grade with a low metal binder content typically has a compressive strength of almost 7,000 N/mm². The compressive strength decreases when the temperature increases. The degree of plastic deformation increases notably with the temperature, so that the results are variable when temperatures are high.

Shear strength

The implementation of pure shear tests is very difficult. However, numerous things speak for the fact that the shear strength is somewhat higher than the compressive strength.

Fatigue strength

The fatigue strength of carbide is above 2 million pulsating compressive loads at around 65 to 85% of the static compressive strength. The compressive fatigue strength increases with a decreasing cobalt content and with decreasing grain size.

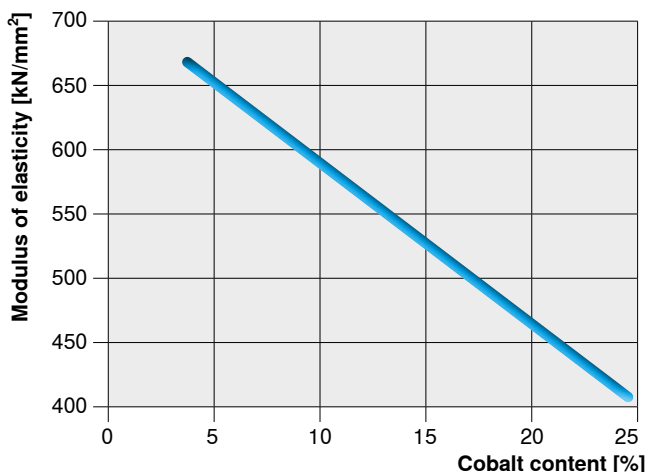

Figure 13: modulus of elasticity of WC-Co carbides

Property	from	to
Hardness [HV30]	1300	2200
Transverse rupture strength [MPa]	2000	4600
Fracture toughness [MPa · m ^{1/2}]		

Figure 14: properties of CERATIZIT round rods and preforms

Modulus of elasticity, shear modulus, Poisson’s ratio

The modulus of elasticity indicates the resistance of a material against elastic deformation and is higher the more rigid a material is. In the case of carbide the modulus of elasticity is 2 to 3 times higher than in steel and increases linearly with decreasing metal binder content. See fig. 13: additives of γ -phase reduce the modulus of elasticity. An exact determination of the modulus of elasticity based on the tension-expansion diagram is difficult. Therefore, for reliable results resonance measurements of transverse and longitudinal waves are carried out according to ISO 3312. The shear module is determined in the same way with the help of torsional vibration. By determining the modulus of elasticity and the shear module the Poisson’s ratio can be calculated.

Influence of the grain size and the cobalt content on the most important properties

The most important mechanical properties of the carbide, such as hardness, transverse rupture strength and fracture toughness, are determined by the grain size of the tungsten carbide and cobalt content. Figure 14 shows the properties of CERATIZIT round rods and preforms. Sporadically it can be sustained that through smaller grain sizes higher hardness and transverse rupture strength can be achieved. At the same time, however, fracture toughness decreases. By increasing the cobalt content hardness is reduced, while the transverse rupture strength and fracture toughness are raised. Based on this fact a compromise between hardness and fracture toughness can be made. Figure 15 shows three different CERATIZIT grades and their hardness, fracture toughness and transverse rupture strength. 0% is the lowest value and 100% the highest value of all CERATIZIT grades.

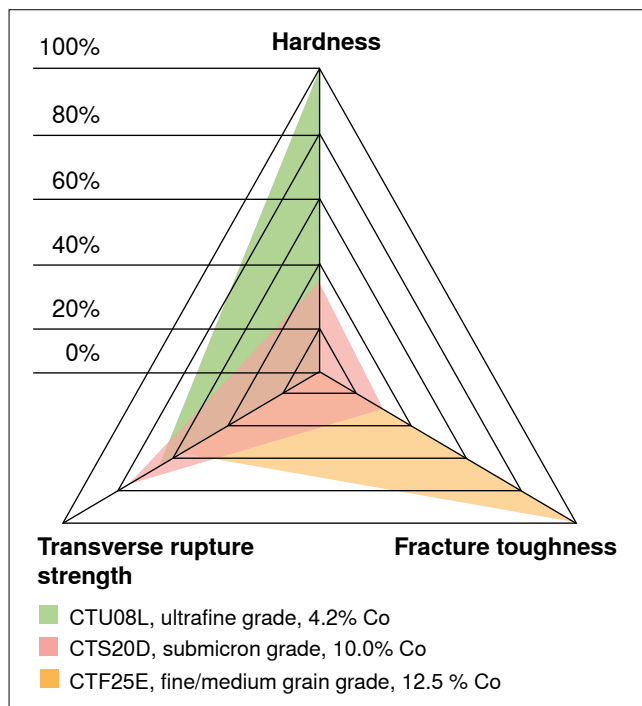

Figure 15: tension fields of three CERATIZIT grades, 0% - lowest value of all grades, 100% - highest value of all grades

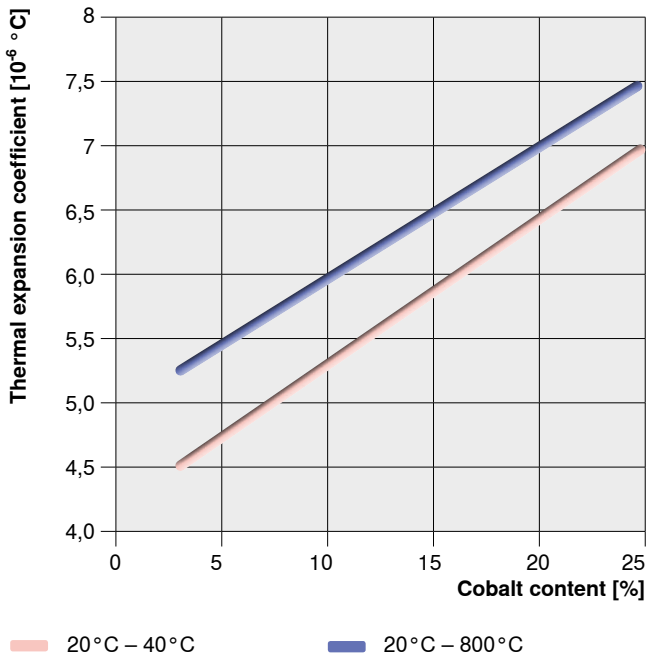

Figure 16: thermal expansion in function of the cobalt content for two temperature intervals

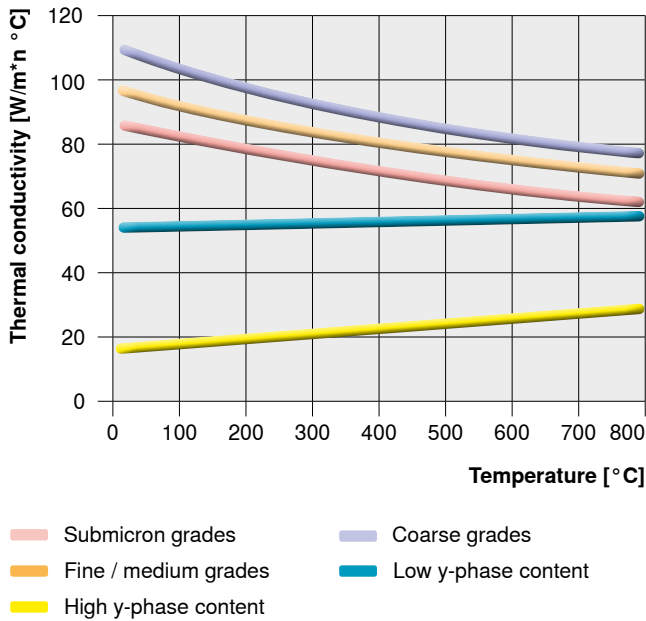

Figure 17: thermal conductivity in relation to the temperature of various micro-structures and grain sizes

Physical properties of carbide

Density

The density of carbide is determined according to ISO 3369 and varies strongly depending on the composition of the carbide grade. Grades with a very high WC content have the highest density. Grades with a high titanium carbide content and a high binder content have the lowest density. Typically it can however be assumed that the density is around 50 to 100% higher than that of steel.

Thermal expansion

As tungsten carbide has a very low thermal expansion coefficient, the values for carbide compared to steel are very low. For carbide grades which contain titanium carbide the values are somewhat higher than for the pure WC-Co carbides. Figure 16 shows the thermal expansion in relation to the cobalt content.

Thermal conductivity

The thermal conductivity is of great significance for carbide applications, as it determines the temperature in the wear areas and has a large influence on the carbide's thermal fatigue resistance and resistance to thermal fluctuations. The thermal conductivity of WC-Co carbide is around twice that of unalloyed steels. It is only slightly influenced by the cobalt content and the grain size, while γ -phases like titanium carbide or tantalum carbide have an impact. Titanium carbide strongly reduces the thermal conductivity. Therefore, for milling grades tantalum carbide is mostly used as γ -phase (see figure 17).

Specific thermal capacity

The specific thermal capacity is the quantity of heat which is necessary to heat up 1 kg of a material by 1 °C. In application technology it is equally important as thermal conductivity, because during the machining processes the heat has to be taken away from the cutting edge. Through a high thermal capacity the surrounding area is less hot as it can absorb more energy.

Specific electric resistance

WC-Co carbides have a low specific resistance of around $20\mu\Omega$ cm and, as such, are good conductors of electricity. Carbides with γ -phases have a higher specific resistance.

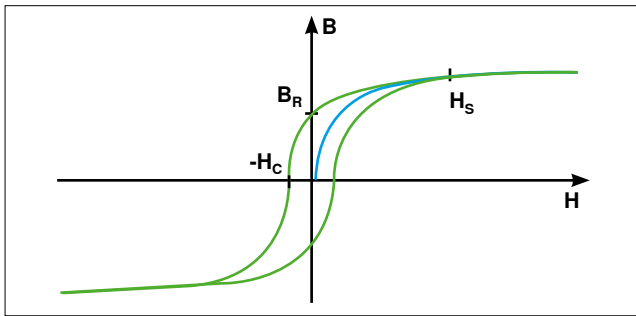

Figure 18: hysteresis curve of a ferromagnetic material

Magnetic saturation & coercive field strength

Carbides with cobalt as a metal binder are ferromagnetic. If a ferromagnetic material is exposed to a magnetic field strength H , the magnetic flux density B in this material increases (figure 18, blue line). The flux density decreases when the field strength rises, until maximum saturation is achieved. This maximum flux density is defined as magnetic saturation ($4\pi\sigma$). When the external field strength is removed, the flux density in the material is reduced along the upper green line to a certain residual magnetism (B_R), the so called 'remnance'. The higher the remanence is, the better a material can be magnetised and the remanence can only be eliminated when the material is subjected to an inverse field. The inverse field strength H_C which is necessary to reduce the magnetic flux density to zero, or to 'de-magnetise' the material, is defined as coercive field strength.

The finer the magnetic field lines of the metal binder phase in the carbide, the higher the coercive field strength. This means that the coercive field strength provides information about the state of the metal binder phase. The metal binder phase becomes finer with smaller tungsten carbide grains and lower binder content. As described in the section on 'Mechanical properties of carbide', the smaller the grains and the lower the metal binder content, the higher the hardness of the structure. In this way an accordant correlation between coercive field strength and hardness can be seen. In practical applications this represents a non-destructive measuring method for the hardness.

The magnetic saturation of carbide also depends on the content and the state of the cobalt binder. When one of these parameters is known, information can be given about the other parameters. In this context the carbon content of the carbide has a decisive influence on the magnetic state of the cobalt. The magnetic saturation provides information about the carburisation of the carbide. This measuring method represents an important tool for checking the production quality.

Permeability

Magnetic permeability means the penetrability of materials for magnetic fields. Although carbide is ferromagnetic, the magnetic permeability values are low. They increase equally along with the magnetic saturation and with the cobalt content and amount to around 5 H/m with 20 vol.%. Compared to this, vacuum has a magnetic permeability of 1 H/m and iron between 300 and 10,000 H/m.

Chemical compounds	Resistance
Acetone	high resistance
Ethanol	high resistance
Sodium hydroxide	high resistance
All acids	low resistance
Tap water	high resistance
Petroleum	high resistance

Figure 19: some chemical compounds and the corresponding resistance of carbide

Corrosion resistance

According to DIN EN ISO 8044 corrosion is a reaction of a metal material with its environment, which causes a measurable modification of the material and may lead to a reduced performance of the metal element or the entire system. In most cases the reaction is electrochemical in nature or in some cases chemical or metallurgical in nature. In carbides corrosion causes a reduction of the surface of the binder phase, thus on the surface there remains only a carbide 'skeleton'. The bond between carbide grains next to each other is very weak, so the rate of destruction increases correspondingly. When the metal binder content is low the carbide 'skeleton' is more pronounced. Consequently this type of carbide grade shows higher wear resistance and corrosion resistance than carbides with a higher metal binder content. In practical applications, however, this is not sufficient to significantly increase the service life. Due to their limited corrosion resistance pure WC-Co carbides are often not suitable for application fields with difficult corrosion conditions. Typically, it can be assumed that WC-Co carbides down to pH 7 are corrosion-resistant.





Headquarters

CERATIZIT S.A.
LU-8232 Mamer
T. +352 31 20 85-1
E. info.ceratizit.com

www.ceratizit.com

Worldwide

CERATIZIT Austria GmbH
AT-6600 Reutte
T. +43 5672 200-0
E. info.austria@ceratizit.com

Brazil

CERATIZIT América Latina Ltda.
BR-13069-310 Campinas,
São Paulo
T. +55 11 4133 2300
E. info.americalatina@ceratizit.com

China

CB-CERATIZIT Xiamen Co., Ltd.
69 Xingxi Road, Xinglin, Jimei,
CN-361022 Xiamen (Jimei), China
T. +86 592 666 1000

Great Britain

CERATIZIT UK & Ireland Ltd.
UK-Sheffield S9 1XU
Toll Free 0800 048 4877 / 4878
T. +44 1925 261 161
E. info.uk@ceratizit.com

India

CERATIZIT India Pvt. Ltd.
IN-Bengaluru 560099
T. +91 80 4043 1262
E. ctindia.info@ceratizit.com

Italy

CERATIZIT Como S.p.A.
IT-22040 Alserio (CO)
T. +39 031 6349 211
E. info.como@ceratizit.com

Japan

CERATIZIT Japan Co.,Ltd.
JP-421-0115 Shizuoka
T. +81-54-268-1060
E. info.japan@ceratizit-j.co.jp

Spain / Portugal

CERATIZIT Ibérica
Herramientas de Precisión S.L.
ES-28660 Madrid
T. +34 91 351 0609
E. info.iberica@ceratizit.com